

Internal distribution code:

- (A) Publication in OJ
(B) To Chairmen and Members
(C) To Chairmen
(D) No distribution

**Datasheet for the decision
of 31 March 2011**

Case Number: T 1351/07 - 3.3.07

Application Number: 02013232.0

Publication Number: 1252921

IPC: B01D 63/02

Language of the proceedings: EN

Title of invention:

Apparatus for withdrawing permeate from a multicomponent
liquid substrate

Patent Proprietors:

Zenon Technology Partnership

Opponents:

Koch Membrane Systems GmbH

Headword:

-

Relevant legal provisions:

EPC Art. 76(1), 111(1), 123(2)(3)

Relevant legal provisions (EPC 1973):

EPC Art. 84

Keyword:

"Main Request - extension of the subject-matter of the patent
as granted beyond the content of the parent application as
filed (yes)"

"Subsidiary Request - Amendments - Allowable (yes)"

"Subsidiary Request - Remittal (yes)"

Decisions cited:

-

Catchword:

-



Case Number: T 1351/07 - 3.3.07

D E C I S I O N
of the Technical Board of Appeal 3.3.07
of 31 March 2011

Appellants:
(Patent Proprietors)

Zenon Technology Partnership
The Corporation Trust Company
Corporation Trust Centre
1209 Orange Street
Wilmington, DE 19801 (US)

Representative:

Cronin, Brian Harold John
CRONIN Intellectual Property
Chemin de Précossy 31
CH-1260 Nyon (CH)

Respondents:
(Opponents)

Koch Membrane Systems GmbH
Kackertstraße 10
D-52072 Aachen (DE)

Representative:

Albrecht, Rainer Harald
Andrejewski - Honke
Patent- und Rechtsanwälte
An der Reichsbank 8
D-45127 Essen (DE)

Decision under appeal: Decision of the Opposition Division of the
European Patent Office posted 15 June 2007
revoking European patent No. 1252921 pursuant
to Article 102(1) EPC.

Composition of the Board:

Chairman: J. Riolo
Members: G. Santavicca
C. Heath

Summary of Facts and Submissions

- I. The appeal by the patent proprietors is against the decision of the Opposition Division to revoke European patent 1 252 921 for extension of the subject-matter beyond the content of the parent application as filed (Article 100(c) EPC).
- II. The patent was granted on European patent application 02 013 232.0, which is a divisional application of earlier European patent application 01 120 849.3 (EP 1 170 052), the latter being a divisional application of earliest European patent application 96 926 288.0 (EP 0 846 023), which originates from international patent application PCT/CA96/00536, published as WO 97/06880 (parent application).
- III. The parent application as filed comprised 14 claims. Independent claim 1 as filed read as follows:
- "1. In a microfiltration membrane device, for withdrawing permeate essentially continuously from a multicomponent liquid substrate while increasing the concentration of particulate material therein, said membrane device including:
- a multiplicity of hollow fiber membranes, or fibers, unconfined in a shell of a module, said fibers being swayable in said substrate, said fibers being subject to a transmembrane pressure differential in the range from about 0.7 kPa (0.1 psi) to about 345 kPa (50 psi);
- a first header and a second header disposed in transversely spaced-apart relationship with said second header within said substrate;

said first header and said second header having opposed terminal end portions of each fiber sealingly secured therein, all open ends of said fibers extending from a permeate-discharging face of at least one header;
permeate collection means to collect said permeate, sealingly connected in open fluid communication with a permeate-discharging face of each of said headers;
and, means to withdraw said permeate;
the improvement comprising,
said fibers, said headers and said permeate collection means together forming a vertical skein wherein said fibers are essentially vertically disposed;
said first header being upper and disposed in vertically spaced-apart relationship above said second header, with opposed faces at a fixed distance;
each of said fibers having substantially the same length, said length being from 0.1% to less than 5% greater than said fixed distance so as to permit restricted displacement of an intermediate portion of each fiber, independently of the movement of another fiber."

IV. The patent in suit as granted comprised 29 claims. Independent Claim 1 as granted read as follows:

"1. An apparatus for withdrawing filtered permeate from a substrate at ambient pressure, comprising:
a header (274,284) having a first face and a second face;
a receptacle (222,282) for collecting permeate, the receptacle (222,282) being in fluid communication with the second face of the header (274,284) and having a permeate outlet (227,285) adapted to be connected to a source of suction;

a plurality of hollow fibre membranes (212), the hollow fibre membranes (212) sealingly secured in the header (274,284) and extending from the first face of the header (274,284), and having ends (212b',212b'') open to the receptacle (222,282) for collecting permeate such that a portion of the substrate drawn into the lumens of the membranes (212) as permeate may flow into the receptacle (222,282); and,

a gas distribution means (240,241,243,245;204,286) adapted to be connected to a source of gas and adapted to discharge bubbles of the gas from near the first face of the header (274,284) from one or more apertures (204,243) located within the plurality of membranes (212),

characterized in that,

the gas distribution means includes a gas delivery tube (245,286) that is oriented generally vertically when the apparatus is in use, said gas delivery tube (245,286) protruding upwards from the first face of the header (274,284) from a location within the plurality of membranes (212) such that the membranes (212) surround the generally vertical gas delivery tube (245,286) where the membranes (212) extend from the header (274,284), said gas delivery tube (245,286) being arranged to deliver gas from the source of gas along and inside the generally vertical gas delivery tube for the gas to be discharged as bubbles via said aperture(s) (204,243).".

- V. The patent had been opposed in its entirety on the grounds that the claimed subject-matter extended beyond the content of the parent application as filed (Article 100(c) EPC) and lacked novelty and an inventive step (Article 100(a) EPC).

- VI. According to the decision under appeal, which was based on the patent as granted (Main Request) as well as on auxiliary requests 1 and 2 submitted with letter dated 16 April 2007, the claimed subject-matter as granted extended beyond the content of the parent application as filed (WO 97/06880) (Article 100(c) EPC). So did the claimed subject-matter of each of the two auxiliary requests. Consequently, the patent was to be revoked.
- VII. In the statement setting out the grounds of appeal, the appellants enclosed a Subsidiary Request as well as new documents A1 to A51 concerning single header modules. In a letter dated 4 January 2011, in preparation for oral proceedings, and in letter dated 24 February 2011, in response to a communication of the Board, the appellants enclosed a Subsidiary Request 2 and a further document (C. Germinario, "*Double Patenting at the European Patent Office*", IP value, 2011) (A52).
- VIII. By letter of 14 May 2008, the respondents submitted their observations on the statement setting out the grounds of appeal and objected to the admission of late filed documents A1-A51 into the proceedings.
- IX. Oral proceedings were held on 31 March 2011. After hearing and questioning the parties on the issue under Article 100(c) EPC (extension beyond the content of the parent application as filed), the Board expressed the preliminary view that the subject-matter of Claim 1 as granted (Main Request) extended beyond the content of the parent application as filed. A potential double patenting arising from the claims concerning systems for withdrawing filtered permeate of the auxiliary

requests over the claims of non opposed patent EP-B-1 170 052 granted on divisional application 01 120 849.3 was then discussed. The appellants withdrew all of the auxiliary requests on file and submitted a freshly amended set of 22 claims as the sole auxiliary request, no longer containing system claims, Claim 1 reading as follows (Compared to Claim 1 as granted, additions are indicated in bold, deletions in strike-through):

1. An apparatus for withdrawing filtered permeate from a substrate at ambient pressure, comprising:

an upper header (273,283) and a lower header (274,284), the lower header (274,284) having a first face which is an upper face and a second face which is a lower face;

a receptacle (222,282) for collecting permeate, the receptacle (222,282) being in fluid communication with the second face of the **lower** header (274,284) and having a permeate outlet (227,285) adapted to be connected to a source of suction;

a plurality of hollow fibre membranes (212), the hollow fibre membranes (212) sealingly secured in the **lower** header (274,284) and extending from the first face of the lower header (274,284), and having ends (212b', 212b'') open to the receptacle (222,282) for collecting permeate such that a portion of the substrate drawn into the lumens of the membranes (212) as permeate may flow into the receptacle (222,282), **wherein the membranes (212) extend between the upper and lower headers and the length of the membranes (212) between opposed faces of the headers is from 0.1% to less than 5% longer than the distance separating said opposed faces;** and

a gas distribution means (240,241,243,245;204,286) adapted to be connected to a source of gas and adapted to discharge bubbles of the gas from near the first face of the **lower** header (274,284) from ~~one or more~~ apertures (204,243) located within the plurality of membranes (212),

characterized in that,

the gas distribution means includes a gas delivery tube (245,286) that is oriented generally vertically when the apparatus is in use, said gas delivery tube (245,286) protruding upwards from the first face of the **lower** header (274,284) from a location within the plurality of membranes (212) such that the membranes (212) surround the generally vertical gas delivery tube (245,286) where the membranes (212) extend from the **lower** header (274,284), **said gas delivery tube (245,286) extending through the upper header (273,283) and acting as a spacer between the upper and lower headers (273,283;274,284)**, said gas delivery tube (245,286) being arranged to deliver gas from the source of gas along and inside the generally vertical gas delivery tube for the gas to be discharged as bubbles via said aperture(s) (204,243).

X. The appellants essentially argued as follows:

Main Request

Extension of the claimed subject-matter as granted beyond the content of the parent application as filed (Article 100(c) EPC)

- (a) The subject-matter of Claim 1 as granted was based on the apparatuses shown in Figures 16 and 17 of both the divisional application as filed, and on

which the patent in suit was granted, and the parent application as filed. Although the apparatus of each of Figures 16 and 17 had upper and lower headers, it nevertheless satisfied the requirement of Claim 1 of having "a header". In fact, each of the features of Claim 1 could be found in the apparatus of Figures 16 and 17, as follows: a header (the lower header) with top and bottom faces (1st and 2nd faces); a receptacle for collecting the permeate; a plurality of membranes fibres (shown on the left side but present on the right side too) fibres, extending from the top face of the header; gas distribution means protruding from the top face of the header. Even if the parent application as filed extensively dealt with embodiments having two headers it did not exclusively address them. Hence, Claim 1 encompassed but was not limited to embodiments with two headers, which embodiment was covered by dependent Claim 17.

- (b) The apparatus with a header encompassed by Claim 1 had an implicit disclosure too in the intermediate product obtained after having potted fibres and air tube in the lower header, the manufacture of which (being part of the manufacture of the apparatuses of Figures 16 and 17) was described in the parent application as filed. The skilled person reading the parent application as filed would have thus contemplated the intermediate product as a further embodiment disclosed.
- (c) The implicit disclosure of the single header module was also supported by one of the two independent and separate problems addressed by the parent

application as filed, namely how to clean the fibres by gas scrubbing (the other being how to deploy the fibres within the substrate), in order to improve the flux or to prevent its quick decline. That the two problems were independent and separate and deserved independent solutions was illustrated by Example 3 (aeration inside the fibres versus aeration outside the fibres) and Example 4 (taut fibres deployed between the headers versus slack fibres). The skilled person would have immediately contemplated that the solution to the first problem (aeration from within and beneath the fibres) was also applicable to single header embodiments, e.g. as obtained when carrying out the disclosed method of manufacture for the embodiments of Figure 16 and 17, as single header modules were known in the art as shown by A1 to A51.

- (d) As to the other end of the membranes extending from the header, its status (open or closed) was not defined in Claim 1, i.e. was not an essential feature. The sealing of that end of the fibres, if any, was obvious for the skilled person wishing to directly use the intermediate product with a header.
- (e) Thus, the definition of only a header for the apparatus of Claim 1 did not extend the subject-matter as originally filed in the parent application, so that the Main Request was allowable.
- (f) As to the relation between implicit disclosure and added subject-matter, T 0211/95 of 9 July 1997 and T 1772/06 of 16 October 2007 were referred to.

Subsidiary Request

Admissibility

- (a) The Subsidiary Request had been filed to overcome the grounds of opposition under Article 100(c) EPC, which prejudiced the maintenance of the granted patent, the double patenting that prejudiced the maintenance of the patent in the amended form of the auxiliary requests, as well as to overcome the objections raised by the Board. The filing of the Subsidiary Request at the oral proceedings being neither an abuse nor a protraction of the appeal proceedings, the Subsidiary Request was admissible.

Amendments

- (b) The amended claims of the Subsidiary Request were based on the application as filed and no longer concerned any systems. The terms objected to as lacking clarity had been amended. The amendments limited the scope of Claim 1, so that no extension of the protection arose.

Grounds of opposition and objections raised

- (c) The Subsidiary Request made clear that the air tube extending from the headers was a spacer, overcame the grounds of opposition by the opponents and the objections by the Board, so that it was allowable.

Remittal or final decision by the Board

- (d) Since therefore the ground of opposition under Article 100(c) EPC had been overcome and novelty and inventive step were no longer contested by the respondents, the case should be remitted to adapt the description to the claims of the Subsidiary Request and for carrying out the correction requested by the appellants (letter of 9 June 2004).

XI. The respondents have essentially maintained that:

Main Request

Extension of the claimed subject-matter as granted beyond the content of the parent application as filed (Article 100(c) EPC)

- (a) Compared to the parent application as filed, which merely disclosed filtration apparatuses having fibres deployed between two headers, Claim 1 as granted comprised at least two extensions, i.e. the fibres extended from a single header and surrounded the air tube, which were not disclosed originally.
- (b) Figures 16 and 17 and Examples 3 and 4, referred to by the appellants as basis for the amendment, in fact concerned filtration apparatuses having two headers holding slack fibres between them. It was the same with all of the other figures of the parent application as filed. Even if the common general knowledge of the skilled person were taken into account, the parent application as filed nevertheless directly and unambiguously disclosed apparatuses with two headers. Documents A1 to A51

neither related to the disclosure of the parent application as filed nor concerned the common general knowledge of the skilled person, so that they should not be admitted in the proceedings.

- (c) As regards the intermediate product with a header obtained during the manufacture of the apparatuses of Figures 16 and 17 of the parent application as filed, it was not a filtration apparatus suitable for filtering water, i.e. it did not fulfil all of the features of Claim 1, or Claim 1 was clearly incomplete in its definition.
- (d) Also the feature that the fibres surrounded the air tube had no explicit disclosure in the parent application as filed, so that it too added subject-matter to the parent application as filed.
- (e) The lacking definition that the air tube extended from and spaced the two headers in the embodiments of Figures 16 and 17 was a further extension over the original disclosure.
- (f) Thus, a filtration apparatus with a single header, with fibres surrounding the air tube, whereby the air merely protruded from the lower header without acting as a spacer between two opposed headers, had no basis in the application as filed, so that more arrangements between fibres and header surfaces than those originally disclosed were encompassed by Claim 1 as granted.
- (g) The generalization served the deliberate purpose of encompassing filtration apparatuses with a single

header and vertically oriented fibres, as disclosed in patent EP-A-1 317 318 of the respondents, which had been maintained in opposition and was in force, hence to gain an unwarranted advantage thereby.

Subsidiary Request

Admissibility

- (h) No objection was raised against the admissibility of the Subsidiary Request.

Amendments

- (i) No objections under Articles 76(1) and 123(2) EPC, or under Article 84 EPC, were raised against the claims of the Subsidiary Request.

Remittal or final decision by the Board

- (j) Since the grounds of opposition of lack of novelty and of an inventive step were no longer maintained, a final decision by the Board was requested.

XII. The appellants (patent proprietors) requested that the decision under appeal be set aside and the patent be maintained as granted (Main Request), or on the basis of the sole Auxiliary Request filed as Subsidiary Request in the oral proceedings.

XIII. The Respondents (opponents) requested that the appeal be dismissed.

Reasons for the Decision

1. The appeal is admissible.

Main Request

2. *Extension of the subject-matter of Claim 1 as granted beyond the content of the parent application as filed (Article 100(c) EPC)*

The Opposition Division revoked the patent in suit for extension of subject matter beyond the content of the parent application as filed, as Claim 1, in view of the feature "An apparatus ... comprising a header ...", encompassed an apparatus having a single header, not disclosed in the parent application as filed.

Although the opponents had also objected to an alleged second extension beyond the content of the parent application as filed, in view of the characterizing features of Claim 1 that the gas delivery tube was surrounded by the fibres, the second alleged extension was not dealt with in the decision under appeal. The respondents have again raised and argued that second extension in the appeal proceedings, both in writing and in oral proceedings.

The Board is primarily called upon to review the decision under appeal on the question of whether or not the subject-matter of Claim 1 extends beyond the content of the parent application as filed having regard to the presence of only one header.

2.1 *Divisional application as filed*

2.1.1 The patent application on the basis of which the patent in suit was granted is a divisional application of earlier European patent application 01 120 849.3 (EP 1 170 052), the latter being a divisional application of earliest European patent application 96 926 288.0 (EP 0 846 023), which originates from international patent application PCT/CA96/00536, published as WO 97/06880 (parent application), hereinafter D0. Thus, the patent in suit follows from a sequence of divisional applications.

2.1.2 According to G 1/06 (OJ 2008, 307, Headnote), "in the case of a sequence of applications consisting of a root (originating application) followed by divisional applications, each divided from its predecessor, it is a necessary and sufficient condition for a divisional application of that sequence to comply with Article 76(1), second sentence, EPC that anything disclosed in that divisional application be directly and unambiguously derivable from what is disclosed in each of the preceding applications as filed".

2.1.3 In the present case, the root or originating application is D0, followed by divisional application 01 120 849.3, which was followed by the patent application on the basis of which the patent in suit was granted.

2.1.4 D0 and the divisional application on which the patent in suit has been granted both contain 14 claims, 50 description pages and 20 figures. Whereas the description and the drawings are identical in both

divisional and parent (D0) applications, none of the (independent) claims of the divisional application as filed, and on the basis of which the patent in suit has been granted, is identical to the claims of D0. In fact, as filed, the claimed subject-matter of the divisional application was amended to an apparatus for withdrawing filtered permeate from a substrate comprising a header, which was not defined as such in the claims of D0.

- 2.1.5 The Board is mindful of the fact that even if the original divisional application complied with Article 76(1) EPC, such would not necessarily be the case with the granted patent. In particular, if the granted patent contains subject-matter that extends beyond the content of the application as filed, in other words does not comply with Article 123(2) EPC, the requirements of Article 76(1) EPC would not be fulfilled, either.
- 2.1.6 However, such is not the case here, as an apparatus for withdrawing filtered permeate from a substrate comprising only a header, as claimed in the divisional application as filed, also makes the subject-matter of Claim 1 as granted, so that the issue of Article 76(1) EPC rather than that of Article 123(2) EPC arises in connection with the sole header.
- 2.1.7 For judging the presence of added subject-matter under Article 76(1) EPC the patent in suit must be compared with the parent application as filed (D0).
- 2.1.8 It is therefore necessary to establish whether or not an apparatus comprising a header was directly and

unambiguously disclosed in D0 (Article 76(1), second sentence, EPC).

The disclosure of D0 (parent application as filed)

3. It is not in dispute that Claim 1 as granted is based on Figures 16 and 17 of the parent application as filed (D0), as these embodiments concern apparatuses with lower headers from which both the fibres and the gas delivery tube protrude, which fact is also acknowledged in the patent in suit (Paragraph [0027], second sentence) (The reference to Figure 8 in the same sentence is a printing error, the correction of which was requested by the patent proprietors with letter dated 9 June 2004). Figures 16 and 17 are reproduced, in reduced scale, herein below.

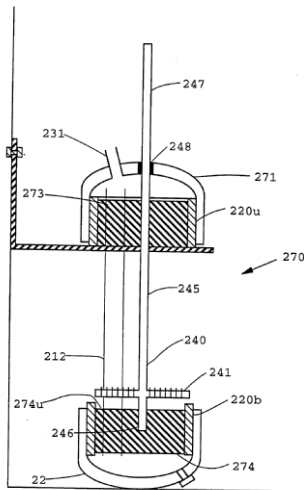

FIG. 16

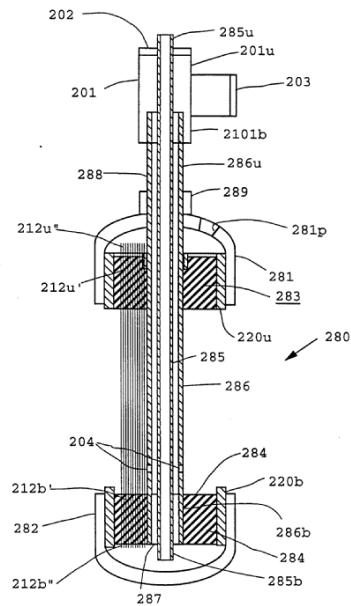

FIG. 17

3.1 Compared to the embodiments shown in Figures 16 and 17, Claim 1 as granted (Point IV, *supra*) contains, in its preamble, the feature "comprising a header", which may

be regarded as a deletion of the further, upper(in use) header as defined in the claims of the parent application as filed (D0).

- 3.2 D0 discloses a number of embodiments, whereby their grouping is *inter alia* based on the type of skein [defined in the glossary of D0 as cylindrical, vertical arrangement having plural arrays of fibres potted in opposed headers, the fibres having a critical defined length relative to the vertical distance between headers of the skein] and headers (cylindrical, parallelepiped), on the presence and arrangement of air tubes and gas distribution systems, etc.
- 3.3 The embodiments shown in Figures 16 and 17 belong to the group of embodiments of Figures 14 to 17, generally presented on pages 8 and 9 and described in detail on pages 34 (starting from line 11) to page 39 (ending at line 17), all having cylindrical skeins, upper and lower end-cap integral headers, in which the fibres are potted, air tube and apertures for the gas, which may be in form of a sparger.
- 3.4 In particular, the embodiments of Figures 16 and 17 are characterized by the additional presence of an air tube potted in the lower header and inserted through the upper header, thus functioning as a spacer means for the headers. The permeate tube may be coaxially located within the air tube, as shown in Figure 17.
- 3.5 It follows from the foregoing analysis of the embodiments of Figures 16 and 17 of D0, invoked by the appellants as basis for Claim 1 as granted, that the apparatus of Claim 1 as granted, which comprises a

- single header, does not belong to any one of the specific embodiments of D0 invoked.
- 3.6 This lack of literal and pictorial disclosure is not in dispute either.
- 3.7 The dispute rather concerns the question of whether or not the combination of the claimed features, all of which per se are shown in the drawings, was allowable in view of the original disclosure.
- 3.8 The appellants argued that D0 also discloses a method of preparing the apparatuses of Figures 16 and 17 and that the claimed combination of features was the inevitable consequence of some of the steps of that method of manufacture, which amounted to an implicit disclosure of an intermediate apparatus available to the skilled person.
- 3.9 It is not in dispute that at a certain point in time during the manufacture of the embodiments of Figures 16 and 17, an intermediate assembly would comprise only the lower header, in which the fibres and the air tube are potted. What is in dispute is whether or not this constitutes an implicit disclosure of an apparatus for (i.e. being suitable for) withdrawing filtered permeate from a substrate as defined in Claim 1.
- 3.10 The Board considers that there is no such an implicit disclosure in D0 of an apparatus as defined in Claim 1 as granted, for the following reasons:
- (a) The ends of the fibres (if not (yet) potted in the upper header) must be appropriately sealed if a permeate is to be withdrawn from the lumen of the

fibres. No such sealing is however disclosed in D0. In fact, the passage referred to by the appellants (last full sentence in the paragraph bridging pages 18 and 19), according to which bundled fibres have their ends dipped in resin or paint, refers to Figure 2, concerning the lower header, and relates to a method usual in the prior art to prevent resin penetration into the bores of the fibres during the potting process, held to be disadvantageous, so that a novel method is taught by D0 that uses two liquids for the potting.

(b) However obvious the sealing of the open ends of the fibres may be for the skilled person, obviousness is not the standard to be applied for assessing extension of subject-matter under Article 123(2) or 76(1) EPC (Case law of the Board of Appeal of the EPO, 6th edition 2010, IV.4.1).

(c) In any case neither the allegedly obvious possibility of sealing the open end of the fibres nor the intention to use the intermediate assembly as a filtration apparatus are disclosed in D0, so that an apparatus with a single header is not disclosed nor hinted at in D0.

3.10.2 An apparatus with a single header cannot be consistent with the disclosure of D0, which is entirely focussed on the application of the discovery that (Summary of the invention, paragraph bridging pages 3 and 4 of D0): "fibers which are more than 5% but less than 10% longer than the fixed distance between the opposed faces of the headers of a vertical skein, tend to shear off at the face; and those 10% longer tend to clump up in the bubble zone; and, a gas-scrubbed vertical skein of restrictedly swayable fibers, provides an optimum

- configuration of fibers through which bubbles of a fiber-cleansing gas ("scrubbing gas") when flowed vertically upwards, parallel to and along the surfaces of the fibers."
- 3.11 Since D0 concerns apparatuses with lower and upper headers, having swayable or slack fibres between them, being suitably gas scrubbed to maintain as high a flux as possible, an apparatus with a single header is not at all envisaged by D0.
- 3.12 Also Examples 3 and 4 of D0 have been referred to by the appellants to show that two distinct problems had been disclosed in D0, one concerning the internal gas scrubbing (versus the external gas scrubbing, as mentioned on page 2 of D0 in connection with the acknowledgement of the prior art), the other concerning the degree of the slackness, which were separate and independent, so that they deserved separate solutions.
- 3.13 However, the apparatuses illustrated Examples 3 and 4 have two headers (according to Figure 16 for Example 3 and with external aeration as shown in Figure 9 for Example 4). The mention on page 2 of D0 concerns the prior art. In fact, there is no direct and unambiguous disclosure of two separate and independent problems in D0, let alone, if any, of the use of the internal gas scrubbing in apparatuses with a single header.
- 3.14 Since D0 does not directly and unambiguously disclose apparatuses having a single header, and since such an apparatus does not implicitly result as an intermediate apparatus from the disclosed method of manufacture, nor as a further solution of the alleged separate and

independent problem of internal gas scrubbing, an apparatus having a single header, however obvious it may be for the skilled person, is alien to the context of the embodiments of Figures 16 and 17 of D0. As no other part of D0 has been invoked to support such embodiment, its introduction in Claim 1 extends beyond the content of D0.

3.15 As regards the implications of decisions T 0211/95 and T 1772/06, invoked by the appellants, to the present case, the former concerns a subject-matter not claimed but disclosed in the parent application as filed, so that it was found (Points 3.3 and 4.4 of the Reasons) that the distinct subject-matter of the divisional application, aiming at solving a particular problem of the parent application as filed with specific features, was unambiguously disclosed in the parent application. The latter concerns subject-matter *inter alia* defined by the feature "solvent-free", which was held to be clear per se (i.e. free of any solvent in absolute terms) and which as such was not implicitly disclosed by the specific conditions for drying as recited in the step "dried ... to remove any remaining solvent", which instead meant "to remove as far as feasible", i.e. which would be such that residual solvent could still be present.

In the present case, even if the intermediate assembly including lower header, fibres and air tube, obtained during the manufacture of a filtration apparatus with two headers, were considered, no filtration apparatus with a header is directly and unambiguously disclosed in the parent application as filed.

Hence, the former decision has nothing to do with the present case, whereas the latter could be seen as being

in line with the conclusions of the Board, i.e. that the direct and inevitable product of the process of manufacture must possess all of the features defined in Claim 1, e.g. be suitable as such for the filtration.

3.16 Furthermore, in Claim 1 as granted also the specification that "said gas delivery tube (merely) protrudes upwards from the first (upper) face of the header from a location within the plurality of membranes ...", not dealt with in the decision under appeal but argued by the parties, finds no basis in the embodiments of Figures 16 and 17, as the gas delivery tube in fact protrudes from both headers and actually act as a spacer. Hence, also the definition given in the characterizing portion of Claim 1 as granted is not directly and unambiguously disclosed in D0.

3.17 For the reasons indicated above, claim 1 as granted does not comply with Article 76(1) EPC. Thus, the Main Request is not allowable and the ground of opposition under Article 100(c) EPC invoked against Claim 1 as granted prejudices maintenance of the patent in suit.

4. *Subsidiary Request*

4.1 *Admissibility*

4.1.1 This request was filed during the oral proceedings before the Board to overcome the grounds of opposition under Article 100(c) EPC and the potential double patenting arising in connection with EP-B-1 170 052, granted on earlier divisional application 01 120 849.3.

4.1.2 Since the Subsidiary Request was filed in reaction to the issues as debated, it is not regarded to constitute an abuse of the proceedings. Nor can an amendment restricting claims to a construction underlying the entire discussion and acknowledged by the respondents as being explicitly disclosed be regarded as a surprise.

4.1.3 Also, since the modifications concerned objections raised by the respondents and the Board and were hand-made on a copy of the previous claims, the contentious nature of the oral proceedings was safeguarded without prolonging the proceedings thereby.

4.1.4 Therefore, the Subsidiary Request is admitted into the proceedings.

4.1.5 Consequently, it only remains to decide whether the further amendments made during the appeal oral proceedings fulfil the requirements of the EPC.

4.2 *Amendments made during the appeal oral proceedings*

4.2.1 Compared to Claim 1 as granted, Claim 1 of the Subsidiary Request comprises the following amendments:

- (a) The presence of upper and lower headers;
- (b) the precision that, for the lower header, the 1st face is an upper face and the 2nd face a lower face.
- (c) The precision that the membranes extend between upper and lower headers and the membranes' length between opposed faces of the headers is from 0.1% to less than 5% longer than the distance separating said opposed faces;

- (d) The deletion of "one or more" before "apertures", thus leaving only apertures.
- (e) The inclusion in the characterizing portion of Claim 1 of the feature "said gas delivery tube (245,286) extending through the upper header (273,283) and acting as a spacer between the upper and lower header (273,283;274,284)".

4.2.2 Claim 17 as granted has been limited to the features of Claim 19 as granted, i.e. granted Claims 18 and 19 have been cancelled, as Claims 20 to 24 as granted.

4.3 *Fair basis for the amendments (Article 123(2) EPC)*

4.3.1 The presence of upper and lower headers is disclosed throughout the parent and divisional applications as filed, in particular is shown in Figures 16 and 17 and correspondingly described in detail.

4.3.2 The specification that the first face is an upper face and the second face a lower face, of the lower header, is just a clearer way of saying how the header looks in use, the vertically oriented being the only disclosed, so that no addition of subject-matter arises here. So does the deletion of one or more before apertures, thus leaving only apertures.

4.3.3 The precision that the membranes extend between upper and lower header and that the length of the membranes between opposed faces of the headers is from 0.1% to less than 5% longer than the distance separating said opposed faces has a basis in the parent application as filed (page 4, lines 22 to 25), as well as in the divisional application as filed.

4.3.4 The feature "said gas delivery tube (245,286) extending through the upper header and acting as a spacer between the upper and lower header has a basis on page 9, lines 17 to 23, of the parent application as filed, hence of the divisional application as filed.

4.3.5 Therefore, the amendments do not extend the claimed subject-matter beyond the content of the application as filed (Article 123(2) EPC), nor beyond that of the parent application as filed (Article 76(1) EPC).

4.4 *Clarity*

The objections under Article 84 EPC raised by the Board in their communication in preparation for the oral proceedings are dealt with by the Subsidiary Request, and the respondents have not raised further objections.

5. *Remittal*

5.1 The decision under appeal found the extension of the subject-matter beyond the content of the parent application as filed the sole ground for revoking the patent. The appeal on this ground has succeeded.

5.2 Claims 1 to 22 of the Subsidiary Request filed during the oral proceedings before the Board overcome the grounds of opposition and the objections raised.

5.3 The examination need not be continued on a new basis according to the above request, as all outstanding grounds of opposition such as lack of novelty and of an

inventive step of the claimed subject-matter have been withdrawn by the respondents and need not be dealt with.

- 5.4 In the exercise of its discretion under Article 111(1) EPC, the Board consequently considers it appropriate to remit the case to the Opposition Division, to adapt the description to the claims of the Subsidiary Request.

Order

For these reasons it is decided that:

1. The decision under appeal is set aside.
2. The matter is remitted to the first instance with the order to maintain the patent on the basis of the Auxiliary Request filed as Subsidiary Request during oral proceedings, with a description to be adapted thereto.

The Registrar:

The Chairman:

S. Fabiani

J. Riolo