

Internal distribution code:

- (A) [] Publication in OJ
(B) [X] To Chairmen and Members
(C) [] To Chairmen
(D) [] No distribution

**Datasheet for the decision
of 15 June 2011**

Case Number: T 0227/08 - 3.3.05

Application Number: 00970713.4

Publication Number: 1147246

IPC: C25C 3/16

Language of the proceedings: EN

Title of invention:

Cathode collector bar with spacer for improved heat balance

Patentee:

Alcoa Inc.

Opponent:

ALCAN FRANCE S.A.S.

Headword:

Collector bar/ALCOA

Relevant legal provisions:

EPC Art. 56

Relevant legal provisions (EPC 1973):

-

Keyword:

"Inventive step (main and auxiliary request): no - improvement
(yes) - technical solution derivable from state of the art"

Decisions cited:

-

Catchword:

-



Case Number: T 0227/08 - 3.3.10

D E C I S I O N
of the Technical Board of Appeal 3.3.10
of -

Appellant:
(Patent Proprietor)

Alcoa Inc.
Alcoa Corporate Center
201 Isabella Street
Pittsburgh
PA 15212-5858 (US)

Representative:

Lenzing Gerber Stute
Partnerschaft von Patentanwälten
Bahnstraße 9
D-40212 Düsseldorf (DE)

Respondent:
(Opponent)

ALCAN FRANCE S.A.S
217 Cours Lafayette
F-69451 Lyon Cedex 06 (FR)

Representative:

Marsolais, Richard
Alcan France S.A.S.
Propriété Industrielle
217 Cours Lafayette
F-69451 Lyon Cedex 06 (FR)

Decision under appeal:

Decision of the Opposition Division of the
European Patent Office posted 18 December 2007
revoking European patent No. 1147246 pursuant
to Article 101(1) EPC.

Composition of the Board:

Chairman: G. Rath
Members: J.-M. Schwaller
S. Hoffmann

Summary of Facts and Submissions

I. This appeal lies from the decision of the opposition division revoking European patent No. 1 147 246 on the basis of Article 100(a) together with Article 56 EPC because the subject-matter of claim 1 of both requests then on file lacked an inventive step over the disclosure of document

A2: SU 1 260 412 A1.

Said claim 1 read as follows:

"1. An electrolytic reduction cell (4) for aluminum production, comprising a cell wall (17,18), a bus bar (46,48) external to said cell wall (17,18), an anode (12), a carbonaceous cathode block (20) separated from said anode (12), and a collector bar (30) connecting said bus bar (46,48) with said cathode block (20), said collector bar (30) comprising:

(a) a ferrous metal body comprising

- 1) a solid, ferrous metal spacer (32) having an external end portion (35) connected with said bus bar (46,48) and an internal end portion (36) spaced inwardly of said external end portion (35), and*
- 2) a ferrous metal sheath (33) defining a cavity (34), and*

(b) a copper insert (40) inside said cavity (34), said copper insert (40) having an external end adjacent said spacer (32), which spacer (32) improves heat balance in the cell by preventing excessive heat transfer between said copper insert (40) and said bus bar (46, 48)."

II. Among the further documents cited during the opposition procedure, the following are of importance for the present decision:

A1: WO 01/63014

A2: SU 1 260 412 and its translations in French and English

A5: US 3 551 319

X2: Cathodes in Aluminum Electrolysis, M. Sørliie and H.A. Øye, 2nd edition, Aluminium Verlag (1994), pages 50 to 52.

The reasons for which the opposition division held the subject-matter claimed to be novel, but not inventive over the disclosure of A2, are in essence as follows:

- In the electrolytic cell according to A2, the sheath of cast iron is located on or around the collector bar, whereas according to the claimed subject-matter it belongs to the collector, therefore novelty was given.
- According to the patent, the problem to be solved lies in the improvement of the heat balance of the electrolytic cell by avoiding excessive heat losses. This problem is supposedly solved by the provision of a ferrous metal spacer located between the bus bar and the copper insert.
- In the electrolytic cell according to A2, the piece of steel connected to the copper implicitly

corresponds to a spacer in the sense of the opposed patent. Steel being known to be a heat conductor worse than copper, the heat balance in the electrolytic cell according to A2 is inevitably improved, too.

- The ferrous metal sheath is part of the collector bar in the subject-matter claimed, whereas in A2 it is located around the collector bar. Since the benefits in terms of heat balance are the same whether the sheath belongs to or is located around the collector bar, the subject-matter thus claimed lacked an inventive step.
- III. With the grounds of appeal dated 18 April 2008, the patentee (hereinafter "the appellant") submitted amended claims 1 and 15.
- IV. With a letter dated 15 October 2008, the opponent (hereinafter "the respondent") raised objections under Articles 54, 56, 83 and 84 EPC.
- V. On 24 November 2008, the appellant submitted four sets of amended claims as a main request and as auxiliary requests 1 to 3, respectively.
- VI. With a letter dated 13 May 2011, the respondent submitted a set of observations along with a new document:
- A7bis: CA 2 258 815
- VII. At the oral proceedings, which were held on 15 June 2011, the discussion first focused extensively on the

validity of the (first) priority claimed from document US 416767 with date of 13 October 1999.

After deliberation on this issue, the board announced its preliminary opinion that the priority date from this document had not been validly claimed and so, the subject-matter of claims 1 of the different requests on file lacked novelty over the disclosure of document A1.

The respondent then dropped all the requests dated 24 November 2008 and submitted two new sets of amended claims as a main request and as an auxiliary request, respectively. These requests were admitted into the proceedings.

Independent claims 1 and 10 of the main request read as follows:

"1. An electrolytic reduction cell (4) for aluminum production, comprising a cell wall (17,18), a bus bar (46,48) external to said cell wall (17,18), an anode (12), a carbonaceous cathode block (20) separated from said anode (12), and a collector bar (30) connecting said bus bar (46,48) with said cathode block (20), said collector bar (30) comprising:

(a) a steel body comprising

1) a solid, steel spacer (32) having an external end portion (35) connected with said bus bar (46,48) and an internal end portion (36) spaced inwardly of said external end portion (35), wherein said internal end portion (36) of the spacer (32) is spaced inwardly of said cell wall (14), and

2) a steel sheath (33) defining a cavity (34), and

(b) a copper insert (40) inside said cavity (34), said copper insert (40) having an external end adjacent said spacer (32), which spacer (32) improves heat balance in the cell by preventing excessive heat transfer between said copper insert (40) and said bus bar (46, 48),

wherein said cathode block (20) defines a slot (24) and said collector bar (30) is seated in said slot (24) for joining said collector bar (30) to said cathode block (24) comprising an electrically conductive material, which is selected from the group consisting of cast iron, carbonaceous glue and rammed carbonaceous paste.

10. A method for producing aluminum in an electrolytic cell having cell walls defining a chamber containing a molten salt bath, an anode contacting the bath, and a bus bar outside the cell walls, said method comprising

a) providing a cathode assembly comprising

1) a carbonaceous cathode block separated from the anode,

2) a steel body comprising a solid, steel spacer having an external end portion connected with said bus bar and an internal end portion spaced inwardly of said external end portion, and a steel sheath defining a cavity, wherein said internal end portion (36) of the spacer (32) is spaced inwardly of said cell wall (14),

3) *a copper insert inside said cavity, said copper insert having an external end adjacent said spacer,*

wherein said cathode block (20) defines a slot (24) and said collector bar (30) is seated in said slot (24), and the cell further comprising means in said slot (24) for joining said collector bar (30) to said cathode block (24) comprising an electrically conductive material, which is selective from the group consisting of cast iron, carbonaceous glue and rammed carbonaceous paste, and

b) passing an electric current from the anode to the cathode assembly, thereby to produce aluminum in said cell."

Independent claim 1 of the auxiliary request differs from independent claim 10 of the main request in that the steel sheath (33) is further defined to be "*integral with said spacer*".

The appellant submitted a further request, in which item 2) in claim 1 of the auxiliary request had been amended to read (amendment underlined by the board):
2) "*a collector bar comprising a steel body comprising a solid, steel spacer having an external end portion connected with [...] and wherein said steel sheath (33) is integral with said spacer (32),*" but the board decided not to admit the request into the appeal proceedings.

VIII. After closure of the debate, the parties' requests were established as follows:

The Appellant requested that the decision under appeal be set aside and that the patent be maintained on the basis of the main request, or alternatively on the basis of the auxiliary request, respectively, both requests filed at the oral proceedings.

The respondent requested that the appeal be dismissed.

Reasons for the Decision

1. *Main request*

1.1 Introduction

This request contains two independent claims, namely claim 1 and claim 10. The board came to the conclusion that none of them meets the requirements of the EPC.

1.2 Claim 1 - Novelty

In view of the outcome of these proceedings on the question of inventive step of claim 10 (see point 1.3 below), it is not necessary to indicate the reasons which led to the conclusion that claim 1 was also not allowable. However, for the sake of completeness, the board briefly points out that it holds the priority document US 416767 not to disclose directly and unambiguously a "spacer improving heat balance in the cell by preventing excessive heat transfer" between the copper insert and the bus bar, and therefore the priority date of 13 October 1999 has not been validly claimed.

As a consequence, document A1 becomes state of the art under Article 54(3) EPC, and its disclosure in association with common general knowledge (document X2, page 80) - that a connection between the cathode block and the collector bar is accomplished by use of room temperature ramming paste, cast iron, carbonaceous glue or cement or thermal expansion fit - anticipates the subject-matter according to claim 1 of the main request, with the consequence that this claim lacks novelty under Article 54(1) and (3) EPC.

1.3 Claim 10 - Inventive step

1.3.1 Claim 10 concerns a method for producing aluminum in an electrolytic cell.

1.3.2 The parties agreed that document A2 represents the closest state of the art. A2 relates to the same technical field as the contested patent - the metallurgy of aluminum by means of the electrolysis of molten salts - and discloses a cathode section arrangement of an aluminum electrolytic cell supposed to solve in particular the problem of reducing the horizontal component of the current.

The proposed cathode arrangement contains a carbon block with a current-conducting bar affixed in it by means of an iron casting, the bar being made of two elements having the same cross section, the element located under the projection of the anode being made of a metal or copper alloy more electrically conductive than aluminum, and the other element being made of a

steel material that is less electrically conductive than aluminum.

In its preferred embodiment - reproduced hereinafter - the cathode arrangement consists of a cathode carbon block 1, a copper bar 4 located under the projection of the anode 5 and a steel bar 3 located in the peripheral portion, with both bars being fixed to the cathode block by means of an iron casting 2 and both bars being joined together by means of welding, friction or any other means.

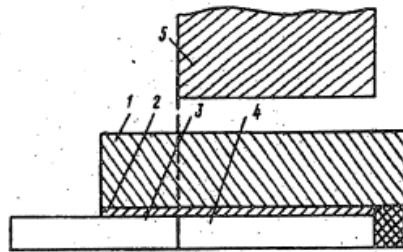

During operation, the current passes from the anode through the electrolyte and reaches the surface of the molten aluminum, and the cathode arrangement assures a reduction of the horizontal current in the aluminum bath. The electrical losses due to the passage of the current through the bottom-copper bar circuit will be lower than along the molten aluminum-aluminum-bottom circuit, as the current flows vertically from the anode to the cathode bar, thus resulting in a decrease of the rate of travel, a decrease of the loss of aluminum and an increase of the current efficiency. The proposed cathode arrangement further makes possible to reuse the metals of the bars. The copper bar can be reused in cathode arrangements after having been cleaned of residues of the iron casting, and the steel bar, which is located in the low temperature zone and so is less subject to oxidation and carburization, can be reused directly. In case aluminum would penetrate the copper

bar and dissolve in it, the contaminated copper bar can in any case be reused in the production of copper alloys.

- 1.3.3 The issue is now to identify the problem underlying the contested patent in the light of document A2.

Initially, the object of the patent in suit (paragraph [0024]) was to provide "a more even cathode current distribution so that the cathode wear rate will be decreased, the pot life will be increased and the operating benefits of the higher graphite and graphitized blocks can be released". The patent specification further describes that the spacer "improves heat balance in the cell by preventing excessive heat transfer between the copper insert and the bus bar" or "reduces the heat losses, compared with collector bars having a copper insert connected directly to the bus bar" (paragraphs [0030] and [0032]).

The board observes that these different problems have already been solved by the electrolytic cell according to document A2, which explicitly discloses the use of the copper bar for reducing horizontal currents in the aluminum bath - in other words to get the so-called "more even cathode current distribution" described in paragraph [0024] of the contested patent. A2 further discloses the use of a steel bar for connecting the copper element to the bus bar - in other words a steel spacer, such as the one defined in claim 10 at issue. Since the steel bar according to A2 is made of the same material as the spacer in the contested patent, it inevitably achieves the same effects as those achieved

in the contested patent, and so - although not explicitly stated in A2 - it implicitly also solves the problem of the heat losses in the electrolytic cell.

At the oral proceedings, the appellant had been requested to identify the technical problem to be solved in the light of A2. It stated that it was to be seen in the provision of a collector bar having an improved mechanical, chemical and thermal resistance. It explained that the steel sheath not only provided an improved resistance to the copper insert, but it also obviated the need for a weld between the steel spacer and the steel sheath and reduced the possibility of damage of the copper-steel link. The appellant further argued that the steel sheath would withhold the copper insert in case the latter would melt as a consequence of overheating of the cell.

The board notes that there is no evidence in the contested patent concerning the above-mentioned improvement regarding the mechanical, chemical and/or thermal resistance of the collector bar, nor does the contested patent indicate the purpose of the steel sheath. As regards the argument concerning the weakness of the copper-steel weld, the board observes that the subject-matter claimed does not exclude the presence of a weld link between the copper insert and the steel spacer, and so this argument cannot be accepted. The argument concerning the possible withholding of copper by the sheath can also not be accepted because a sheath is not necessarily closed and so a sheath in the sense of the contested patent may suffer from leakages in case of copper melting.

In view of the above remarks, the problem has to be reformulated and the board can accept the respondent's argument that the technical problem could be seen in the provision of an improved lifetime for the collector bar, since the respondent confirmed that a steel sheath would offer a better protection to the copper insert than the iron casting known from A2.

- 1.3.4 As a solution to this technical problem, the patent proposes the method for producing aluminum in an electrolytic cell according to claim 10, characterised in particular in that the cell comprises a cathode assembly comprising a steel body with a steel spacer having an external end portion connected with the bus bar and an internal end portion spaced inwardly of said external end portion, and a steel sheath defining a cavity in which is located a copper insert having an external end adjacent said spacer.
- 1.3.5 Insofar as the respondent itself recognised that the steel sheath provided an improved lifetime to the collector bar, the board - in spite of the absence of examples in the patent in suit - is satisfied that the problem under point 1.3.3 above has been solved.
- 1.3.6 It remains to be decided whether the proposed solution is obvious to the skilled person in view of the state of the art. In this respect, the board observes that the skilled person cannot ignore the content of document A7bis, which is from the same technical field as the contested patent, since it discloses a collector bar particularly adapted for utilisation with a carbon block during the production of molten metal, such as

aluminum, under Hall-Heroult applications (A7 bis, claim 1; abstract).

Document A7bis discloses in particular (page 1, first paragraph) a collector bar constructed as a one-piece drawn metallic tube of relatively low electrical conductivity and a one-piece rod of relatively high electrical conductivity, such as copper, with the tube being in encircling relationship to the rod. Preferably, the rod is relatively elongated, substantially polygonal in transverse cross section and has opposite longitudinal edge portions which are in intimate surface-to-surface contact with opposite interior surface portions of the tube. One end of the tube is preferably closed by a ferrous end cap and the copper rod is exposed at the end of the collector bar opposite the end cap for connection to a source of electrical power. The tube is seated in a slot of a carbon block and is bonded thereto by cast iron or similar suitable bonding material. Preferably, the exterior tube is made of a ferrous material drawn or extruded as a continuous tube, with the tube having an opening or bore into which an identically exteriorly sized copper rod can be inserted, preferably when the ferrous or steel tube is warm so that upon insertion of the identically dimensioned copper rod, the steel tube will cool to intimately retain the copper rod therein. The tube may have a plurality of slots along a corner edge thereof through which tack welding can be utilised to secure the copper rod immovably within the steel tube.

The figures in A7bis, in particular Figures 2 and 7 reproduced hereinafter, illustrate a collector bar

which is bonded to the carbon cathode block (B', B''') by means of cast iron (CI', CI''') and includes a one-piece extruded or drawn metallic tube (11, 21''') of relatively low conductivity and high strength, such as steel, which tube defines a cavity into which is inserted a copper rod (13, 23''') and the end portion (14, 27''') of which includes an opening (15, 25''') for connecting a current-carrying cable to the rod (D17, page 14, lines 16 to page 15, line 2).

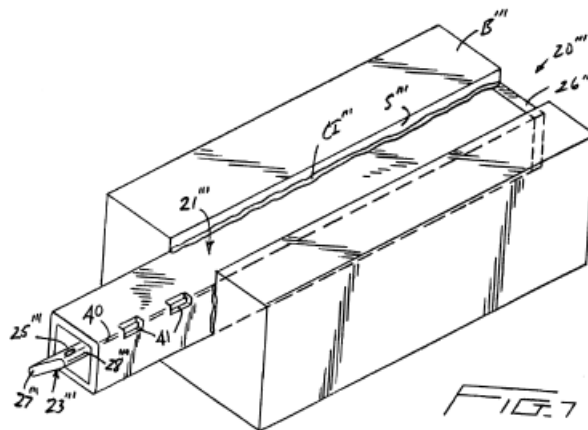
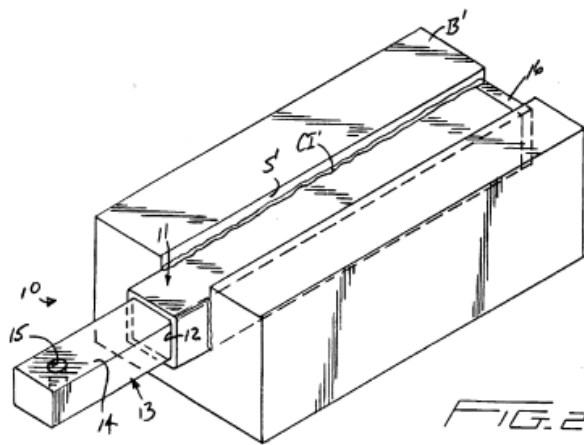

1.3.7 Although the part of the collector bar located between the cathode block (B, B''') and the opening (15, 25''') for connecting a current-carrying cable to the rod might be assimilated to a "spacer", the subject-matter of claim 10 differs from the electrolytic cell

according to A7bis, since it does not disclose that the "spacer" is made of **steel**.

1.3.8 The object of A7bis was to provide a cathode collector bar which is extremely inexpensive to manufacture and yet provides both high electrical conductivity and **long life** (*emphasis added by the board*) (page 1, first three lines). The inventors in A7bis explained (second full paragraph, page 1) that their starting point - document A5 - disclosed "*a cathodic current collector formed by an L-shaped or U-shaped ferrous material sheath which houses a copper core and is closed by one or more ferrous blocks, all of which are welded to each other and suitably installed in the cell lining of a conventional reduction cell spaced about and supported by a plurality of carbon blocks. The copper core reduces resistance to achieve efficient current flow, whereas the current sheath affords shielding/protection. However, the cost of fabrication of the relatively complex cathodic collector is quite high due to both the cost of materials involved, as well as the assembly thereof*" (The board observes that the passage reproduced above is verbatim cited in A7bis (page 1, lines 1 to 8 from the bottom),

Hence, A7bis directly and unambiguously informs the skilled person that the ferrous material metallic sheath in the collector bar provides for a protection and for a longer life of the copper core.

1.3.9 The board is of the opinion that in view of this teaching, the skilled person faced with the problem identified under 1.3.3 - in particular the achievement of a longer life as regards the cathode collector bar

known from A2 - would inevitably be prompted to use the "one-piece extruded or drawn metallic tube of relatively low conductivity and high strength, such as steel" in "encircling relationship to the one-piece rod of relatively high electrical conductivity, such as copper" disclosed in A7bis, and so arrive at the subject-matter according to claim 1 at issue with a reasonable expectation of success, since the aim of the one-piece metallic tube in the electrolytic cell according to A7bis is to protect and so, to provide the copper core with a longer lifetime.

- 1.3.10 The board cannot accept the appellant's arguments that the teaching of A7bis and A2 could not be combined for the following reasons.

The argument that the collector bar design of A2 was "most probably unworkable" has not been substantiated by any piece of evidence. That the collector bar requires a joint between the full cross sections of the copper and the steel part is correct, however A2 does not specify that the joint be vertical, let alone that the two parts are to be joined by welding. A2 simply specifies that the "two bars are joined to each other by some means (welding, friction, etc.)" and the use of such a joint is unambiguously encompassed by the subject-matter of claim 10 at issue. The respondent further argued that the copper-steel joint in A2 was subjected to influences - such as "frost heaving" or weakness of the copper-steel joint - which put it at considerable risk for breakage; this might be true, however no evidence has been provided and in any case, as explained hereinbefore, the type of joint disclosed

in A2 is unambiguously encompassed by the subject-matter claimed.

Concerning the line of argument that the steel sheath would retain the copper in case of melting at high temperature excursion of the electrolytic cell, it is observed that a sheath can be open - as evidenced by the citation in A7bis (second full paragraph in page 1) that the sheath according to A5 was "L-shaped or U-shaped" - and so permeable to any fluid leakage.

The subject-matter according to claim 10 (indirectly) defines the copper insert to extend at the maximum up to the cell wall and so, it clearly includes the embodiment according to A2, wherein the copper part is located under the projection of the anode.

Therefore, the disclosure of A2 does not form an obstacle for a combination with the teaching of A7bis.

1.3.11 In view of the above findings, it is concluded that having regard to the state of the art, the subject-matter of claim 10 is obvious for a skilled person and so, claim 10 does not involve an inventive step within the meaning of Article 56 EPC.

2. Auxiliary request

2.1 The subject-matter of claim 1 of this request is distinguished from the subject-matter of claim 10 of the main request in that the steel sheath (33) is "*integral*" with the spacer.

2.2 The meaning of the word "integral" has been disputed by the parties and the appellant argued in particular that meant "made of one part".

The board cannot accept this argumentation, as there is no basis in the contested patent for such a restrictive interpretation. The disputed term has therefore to be interpreted in its broadest way, namely "made up of parts forming a whole", as proposed by the respondent.

2.3 With respect to the assessment of inventive step, and in particular the problem to be solved, the appellant argued that in the light of A2 the definition of the problem could be expanded and explained that the major advantage of the steel sheath made "integral" with the steel spacer was arising from the fact that in case the copper insert would melt as a result of overheating of the cell, the melted copper would be withheld in the steel sheath and after cooling of the collector bar, the copper insert would so remain more or less intact.

The board cannot accept this argument, because as explained hereinbefore (item 1.3.10), a sheath is not necessarily closed and so, melted copper leakages from the steel sheath "integral" with the steel spacer are still possible.

In this context, starting from A2 as the closest state of the art, the problem to be solved is the same as with respect to the main request, namely to provide a collector bar having an improved lifetime.

2.4 As a solution to this problem, the contested patent proposes the method for producing aluminum in an

electrolytic cell according to claim 1 of the auxiliary request , characterised in particular in that the cell comprises a cathode assembly comprising a steel body with a steel spacer having an external end portion connected with the bus bar and an internal end portion spaced inwardly of said external end portion, and a steel sheath integral with said spacer and said steel sheet defining a cavity in which is located a copper insert having an external end adjacent said spacer.

- 2.5 As indicated hereinbefore, it is credible that the steel sheath offers a better protection to the copper insert than the iron casting disclosed in A2. Furthermore, the fact that the steel sheath is integral with the steel spacer credibly increases the mechanical durability and so, the lifetime of the collector bar. The board is therefore satisfied that the problem has effectively been solved by the proposed solution.
- 2.6 As to the question whether or not the proposed solution is obvious in view of the state of the art, the board observes the following:
- 2.6.1 Concerning the presence of a steel sheath around the copper core, the reasons as to why this feature is rendered obvious by the state of the art are set out under points 1.3.2 to 1.3.10 above; they apply *mutatis mutandis* to the subject-matter of claim 1 of this request.
- 2.6.2 Regarding the other advantage, namely an improved mechanical stability due to the link between the steel sheath which has been made integral with the steel spacer, this advantage can be readily contemplated in

advance for a person skilled in the art and, so it lies within the competence of the skilled practitioner seeking an improved mechanical stability and lifetime for the collector bar. It is to be noted that this feature is even taught in the embodiment disclosed in Figure 7 of document A7bis, because the part of the collector bar located between the cathode block (B''') and the opening (25''') for connecting a current-carrying cable to the rod (23''') can be assimilated to a "spacer". As the steel sheath in this embodiment furthermore has a plurality of slots along a corner edge through which the inner rod can be secured immovably within the steel tube by means of tack welding (A7bis: page 2, last paragraph; sentence bridging pages 5 and 6), the steel tube (21''') is so made integral with the rod (23''') in this specific embodiment.

Bearing in mind this teaching, the skilled person faced with the problem defined in point 2.3 above would arrive in an obvious manner at the subject-matter of claim 1 of the auxiliary request, since the latter is derivable from the state of the art document A7bis. That a piece of metal made integral with another piece of metal would have an improved mechanical strength and lifetime is common general knowledge. Claim 1 of this request therefore lacks an inventive step within the meaning of Article 56 EPC.

3. In conclusion, none of the sets of claims at issue meets the requirements of Article 56 EPC, so none of the appellant's requests is allowable.

4. The further request submitted at the oral proceedings has not been admitted into the appeal proceedings because it has been filed late. The appellant was well aware before the oral proceedings of the clarity problem engendered by the missing antecedent for the expression "said collector bar" in claim 1 - the respondent already mentioned this deficiency in its letter dated 13 May 2011 (point VIII, page 18) - and so it could have filed this amendment at a much earlier stage. This late-filed request would furthermore not have modified the outcome of this decision, since the only amendment made - clarification of the missing antecedent for the expression "said collector bar" - would not have permitted to overcome the lack of inventiveness of the subject-matter of claim 1 at issue.

Order

For these reasons it is decided that:

The appeal is dismissed.

The Registrar:

The Chairman:

C. Vodz

G. Rath