

**Internal distribution code:**

- (A) [ - ] Publication in OJ  
(B) [ - ] To Chairmen and Members  
(C) [ - ] To Chairmen  
(D) [ X ] No distribution

**Datasheet for the decision  
of 26 October 2018**

**Case Number:** T 2157/13 - 3.2.02

**Application Number:** 05766440.1

**Publication Number:** 1790363

**IPC:** A61M1/14

**Language of the proceedings:** EN

**Title of invention:**  
BLOOD PURIFICATION APPARATUS

**Patent Proprietor:**  
NIKKISO COMPANY, LTD.

**Opponent:**  
Fresenius Medical Care Deutschland GmbH

**Headword:**

**Relevant legal provisions:**  
EPC Art. 56  
RPBA Art. 13

**Keyword:**  
New objection - not admitted  
Inventive step - (yes)

**Decisions cited:**

T 0570/91, T 0439/92, T 1040/93, T 0817/94

**Catchword:**



**Beschwerdekammern**

**Boards of Appeal**

**Chambres de recours**

Boards of Appeal of the  
European Patent Office  
Richard-Reitzner-Allee 8  
85540 Haar  
GERMANY  
Tel. +49 (0)89 2399-0  
Fax +49 (0)89 2399-4465

Case Number: T 2157/13 - 3.2.02

**D E C I S I O N**  
**of Technical Board of Appeal 3.2.02**  
**of 26 October 2018**

**Appellant:** Fresenius Medical Care Deutschland GmbH  
(Opponent) Else-Kröner-Strasse 1  
61352 Bad Homburg (DE)

**Representative:** Rau, Jenspeter  
Fresenius Medical Care AG & Co. KGaA  
Global Intellectual Property  
Frankfurter Straße 6-8  
66606 St. Wendel (DE)

**Respondent:** NIKKISO COMPANY, LTD.  
(Patent Proprietor) 43-2, Ebisu 3-chome  
Shibuya-ku,  
Tokyo 150-8677 (JP)

**Representative:** Grosse Schumacher Knauer von Hirschhausen  
Patent- und Rechtsanwälte  
Nymphenburger Strasse 14  
80335 München (DE)

**Decision under appeal:** **Decision of the Opposition Division of the  
European Patent Office posted on 6 August 2013  
rejecting the opposition filed against European  
patent No. 1790363 pursuant to Article 101(2)  
EPC.**

**Composition of the Board:**

**Chairman** E. Dufrasne  
**Members:** P. L. P. Weber  
D. Ceccarelli

## **Summary of Facts and Submissions**

- I. The appeal of the opponent is against the decision of the opposition division dated 6 August 2013 to reject the opposition.
- II. Notice of appeal was filed 10 October 2013. The appeal fee was paid on the same day. The statement setting out the grounds of appeal was filed on 6 December 2013.
- III. The documents cited in the appeal are:
- A1: WO-A-98/17334  
A2: WO-A-01/45770  
A3: WO-A-96/08305  
A4: DE-A-195 28 907
- IV. The parties were summoned to oral proceedings by letter dated 17 July 2018.
- V. By letter dated 13 September 2018, the appellant/opponent substantiated for the first time in the appeal proceedings an objection of lack of inventive step starting from document A4 as the closest prior art.
- VI. Oral proceedings were held on 26 October 2018.

The appellant/opponent requested that the decision under appeal be set aside and that the patent be revoked.

The respondent/patent proprietor requested that the appeal be dismissed.

VII. Claim 1 reads as follows (feature numbering introduced by the Board):

"1.1 A blood purification device comprising:

1.2 a blood circuit route (1) having an arterial blood circuit route (1a) and a venous blood circuit route (1b) to circulate extracorporeally the blood collected from a patient;

1.3 a blood pump (3) provided in said arterial blood circuit route;

1.4 a blood purification means (2) connected between said arterial blood circuit route and said venous blood circuit route, and purifies the blood flowing in said blood circuit route;

1.5 a blood concentration means (8) to provide a specific peak in blood concentration by concentrating the blood;

1.6 a detecting means to detect the specific peak provided by said blood concentration means;

1.7 said purification device adapted to detect re-circulated blood flowing in said arterial blood circuit route, the re-circulated blood being blood that was returned to the patient from said venous blood circuit route but again directed to the arterial blood circuit route, based on the specific peak measured by said detecting means;

characterised in that

1.8 said detecting means comprises the first detecting means (5a) provided to said arterial blood circuit route and

1.9 the second detecting means (5b) provided to said venous blood circuit route."

VIII. The arguments of the appellant/opponent relevant for the decision can be summarised as follows (see the reasons for the decision for more details):

An objection starting from A4 had to be admitted into the proceedings because it was more relevant than the documents on file and not complicated for the other party and the Board to understand.

The subject-matter of claim 1 was not inventive when starting from A1 in combination with A3, when starting from A3 in combination with the common general knowledge or with either A1 or A2.

IX. The arguments of the respondent/patent proprietor are essentially those underlying the reasons for the decision.

### **Reasons for the Decision**

1. The appeal is admissible.
2. The invention

The invention is for detecting recirculation in the fistula during a dialysis treatment. Fistula recirculation occurs when some of the treated blood that passed through the dialyser and returned to the patient's venous system circulates through the arterial

blood line back to the dialyser for a second time. For detecting recirculation it is known in the state of the art to create a disturbance in the venous line and to detect any corresponding change in the arterial line. However, a change detected in the arterial line is not necessarily due to the disturbance created in the venous line. The invention proposes to produce a specific blood value peak (e.g. hematocrit) in the venous line (for instance, by accelerating the ultrafiltration pump for a short time, Figure 3) and to detect that peak in the venous line (Figure 4). Detecting the peak created in the venous line ensures that the peak detected in the arterial line (Figure 5) is not present due to another reason.

Fig. 3

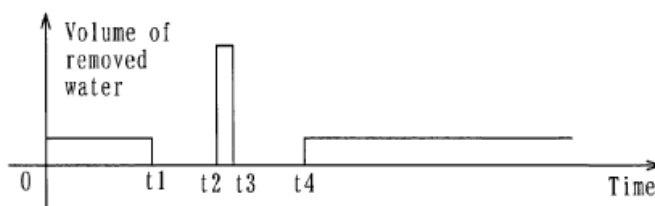

Fig. 4

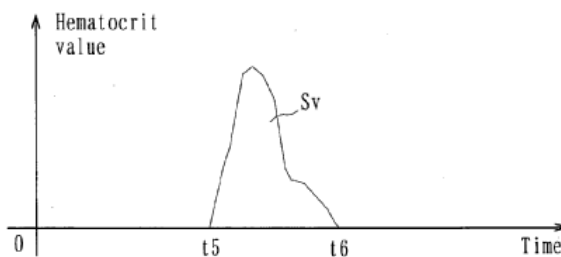
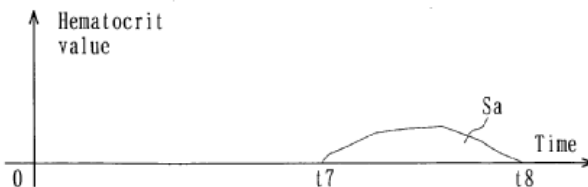

Fig. 5



3. Inventive step - Admissibility of the objection starting from document A4

The appellant considered that the substantiation of the objection was a reaction to the opinion of the Board expressed in the summons that no objection starting from A4 was substantiated in the appeal proceedings. Furthermore, the discussion of this document did not lengthen the proceedings or make them more complicated for the respondent since the respondent had taken a position on that document in its reply to the statement setting out the grounds of appeal. More importantly, this document had to be admitted into the proceedings because it was more relevant than documents A1 and A3 on file. The device disclosed in this document worked with two sensors, one in the arterial line and one in the venous line. It also did not need a separate injection since it diluted the blood with the dialysate present in the device. Even if in this document other parameters were measured, it was also possible to measure the local recirculation in the fistula.

This objection was substantiated for the first time after the summons, approximately six weeks before the oral proceedings, and no justification was given for the late substantiation. Thus, pursuant to Article 13 RPBA, this amendment to the appellant's case will be admitted into the proceedings and considered at the Board's discretion.

Document A4 discloses a method for determining several dynamic parameters of a dialysis treatment (cardio-pulmonary recirculation, fistula flow, cardiac minute flow). In particular, this document considers it important to provide a method for determining the cardio-pulmonary recirculation and the fistula flow without manual intervention (page 2, lines 59 to 61 and page 3, lines 15 to 19). The method is based on



recirculation measurements before and after inversion of the blood flow (e.g. page 3, lines 21 to 28) between the arterial and the venous lines. However, the document makes no mention of determining local recirculation in the fistula. On the contrary, the document explains that to obtain good results, local recirculation is detrimental and, hence, should be avoided (page 7, lines 9 and 10). In the context of this document, this makes technical sense since the cardio-pulmonary recirculation is far lower than the local recirculation in the fistula. And since one aim in A4 is to measure that cardio-pulmonary recirculation, any local recirculation influencing the measurement should consequently be avoided. This is also why the chosen blood flow for the measurement should be significantly lower than the fistula flow, as indicated in the same lines on page 7. Indeed, the closer the blood flow comes to the fistula flow, the higher the risk of having local recirculation in the fistula, and thus an influence on the measurement of the cardio-pulmonary recirculation.

Moreover, the "disturbance" in the venous line used for the measurement is not created according to the same principle of concentrating the blood as required by the claim wording but by diluting the blood with dialysate, and the observation time of 10 minutes mentioned on page 6, lines 29 to 34, suggests that dilution time is not as short as meant by the peak required by the claim.

Therefore, in the Board's opinion, this document is not more relevant than the documents on file. Thus, the Board decides to not introduce it into the appeal proceedings pursuant to Article 13 RPBA.

4. Inventive step - starting from A1

In this document, re-circulation is detected after raising the blood concentration in the venous line by increasing ultrafiltration, as in the embodiment described in the patent in suit. More specifically, the dialysate flow is stopped until the concentration of electrolytes is identical in blood and dialysate (page 8, lines 29 to 32), the ultrafiltration pump is stopped (page 9, lines 3 to 7), the haemoglobin concentration in the arterial line is measured, the ultrafiltration pump is started at a given value for a given time. If there is re-circulation, the value of haemoglobin concentration increases in the arterial line; otherwise, it does not (page 9, line 14 to page 10, line 14). In the embodiment described, the "disturbance" used for the measurement lasts 5 minutes (page 9, lines 14 to 19). In other words, it is not a peak but a higher level of ultrafiltration for 5 minutes.

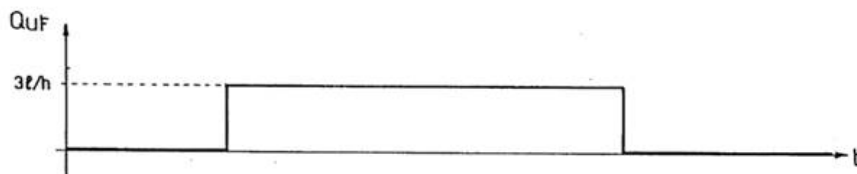

Fig.5

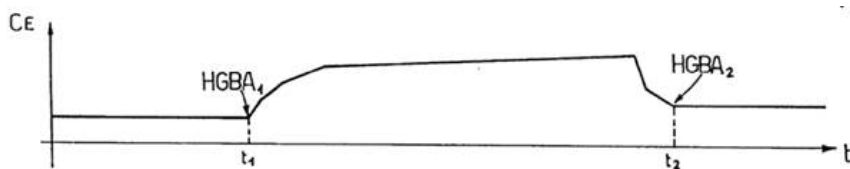

Fig.7

From the above it follows that features 1.5 and 1.9 are not disclosed in A1. There is no specific peak created in the venous line and there is no second means of detection in that line.

The appellant considered that the respondent had recognised that a higher level of ultrafiltration also fell under the wording of a "specific peak" used in the claim because the introductory part of the description in the patent in suit identified a Japanese family member of A1 and explained that that document disclosed the measuring of the recirculation using a specific peak.

The Board does not share this opinion since it is clear from the descriptions and figures of the two documents, in particular Figures 3 and 4 of the patent in suit and Figure 5 of A1, that the kind of disturbance meant is different.

The technical effect of using a specific peak and a second sensor in the venous line is that during the measuring process the disturbance is clearly identified and that there is no doubt that the disturbance measured in the arterial line is due to the disturbance induced in the venous line and not anything else (a problem with the pump, the patient moving, etc.). This makes the measuring process more reliable and possibly shorter, and the patient does not have to suffer changes in the therapy parameters.

The objective technical problem can therefore be seen as one of making the measuring process more reliable and less disturbing for the patient.

Starting from A1, the appellant considered that the subject-matter of claim 1 would be obvious in view of A3, in particular since that document suggested using two sensors as exemplified in Figure 5 (sensor 80) or in Figure 7 (sensor 130). It was self-evident that when

such a second sensor was used, it was used for each measurement performed. In any case, the wording of claim 1 did not indicate the function of the second sensor. So using it for calibration was not excluded by the claim.

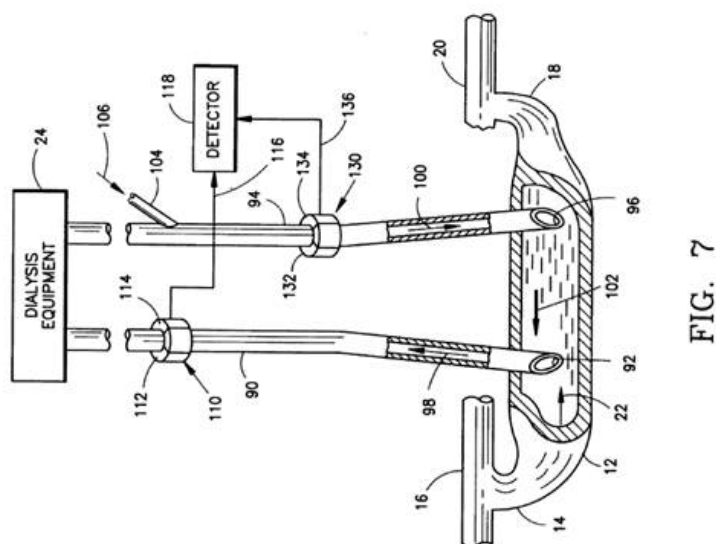

FIG. 7

The device disclosed in A3 is based on a measurement principle different to blood concentration. In this device, to measure the recirculation in the fistula, a specific amount of dilution fluid (saline) is injected into the venous line and the change of a property of the blood (sound transmission) is measured in the arterial line, which is an indication of recirculation. In several embodiments, the circulation direction is reversed compared to the normal one, only the embodiment of Figures 6 and 7 has the inlet needle and outlet needle arranged in the usual way in the fistula. In order to avoid the influence of the tubing wall on the measurements, either a calibration injection is made in the arterial line or the calibration injection is replaced by a sensor in the venous line (page 9, lines 1 to 7; page 15, lines 14 to 16; page 17, lines 21 to 25).

In the Board's opinion, it is common general knowledge that calibration is not usually done for each measurement. On the contrary, calibration is usually performed to make sure, at the beginning of a series of measurements or when a new machine is installed or started, that all the sensors are ready and able to deliver the right information expected from them so that no false measurements are provided to the control unit. In the absence of different information in A3, it cannot be supposed that the author of that document had a different approach. Hence, in the Board's opinion, it has not been established that the second sensor mentioned in relation to Figure 5 or 7 would be for any function other than calibration, i.e. for a one-time measurement in a series. In other words, it has not been established that for each measurement both sensors are active and provide information to the controller. In the context of A3, this does not seem technically necessary since the disturbance, i.e. the volume of indicator (saline) injected into the venous line for each measurement, is known (page 2, line 24 to page 3, line 5; page 4, lines 2 to 6). Thus, it is not necessary to determine it for each measurement.

Hence, in the Board's opinion, the person skilled in the art starting from A1 wishing to improve the accuracy of the measurement and the well-being of the patient would not arrive in an obvious way at the subject-matter of claim 1 because even if the second sensor described in A3 were adopted, it would still not be used for determining the recirculation, only for calibration. Moreover, one aim of the invention disclosed in A1 is to reduce the number of sensors (page 12, lines 14 to 16), which is seen in this document as a way to reduce measurement errors. This is

an additional reason why the person skilled in the art starting from A1 would not introduce additional sensors, something the author of A1 wished to avoid.

The appellant considered that the function of the second sensor was not indicated in the claim and therefore it could not play any role for inventive step.

In the patent in suit, the object of the invention is mentioned in paragraph [0006] and is "*to provide a blood purification device for confirming whether a specific peak has been given by a blood concentration means or not, ...*". The solution to this problem is the provision of the second sensor as claimed in claim 1. Thus, it is self-evident from the patent as a whole that the function of the second sensor is to confirm that a specific peak was created by the blood concentration means.

Hence, the subject-matter of claim 1 is inventive starting from A1 in combination with A3.

5. Inventive step - starting from A3

The appellant considered that claim 1 was also not inventive starting from A3, either in combination with common general knowledge or in combination with A1 or A2.

As mentioned above, the measuring principle in A3 is based on dilution of the blood by injection of saline whereas claim 1 requires blood concentration. Thus it is already questionable whether this document can be considered a realistic starting point. But it would

anyway follow that at least the measuring principle is a differentiating feature.

6. The appellant considered that the person skilled in the art seeking to improve the measuring method of A3 would adopt the blood concentration principle disclosed in A1 or A2. The person skilled in the art would be all the more likely to do this given that A1, on page 19, teaches that the disturbance provoked in the blood for measuring recirculation can be a decrease or increase of the quantity of plasmatic water contained in the blood.

In the Board's opinion, the above is a hindsight reasoning. Indeed, there is no obvious reason why the person skilled in the art would abandon the basic measuring principle used in the apparatus it wishes to improve (T 0570/91, point 4.; T 0439/92, point 6.2.4; T 0817/94, point 5.5; T 1040/93, point 5.). Even if the person skilled in the art took A1 into consideration for seeking any improvement in the apparatus disclosed in A3, it would still not abandon the dilution principle used therein. In other words, even when considering A1, the person skilled in the art would at most replace the dilution by injection in A3 by a dilution with plasmatic water in A1, and thus would still not arrive in an obvious manner at the subject-matter of claim 1.

Document A2 basically develops the method according to A1 in that it uses continuous variations (increases and decreases around an average value) of the haemoglobin concentration created by changing the rate of the ultrafiltration pump (page 9, line 11 to page 10, line 21). In this way, continuous or real-time monitoring of the recirculation is possible, as opposed to the one-

shot created variation in A1, for instance. Thus, for the same reason as A1, this document cannot lead the person skilled in the art in an obvious way to the subject-matter of claim 1. On the contrary, it even suggests abandoning the creation of a specific peak and replacing it with a continuous variation.

7. The appellant considered that A3, on page 12, lines 7 to 11, taught that heated or cooled blood could be used as an indicator. Thus, based on this statement, there would be no inventive step in the person skilled in the art choosing a higher or lower blood concentration as a disturbance.

This, too, is hindsight reasoning. The cited paragraph explains that normally saline (which has different sound velocity properties) is injected into the venous line but heated or cooled blood could be used instead. There is no specific embodiment disclosed in A3 using this principle, so it must be supposed that it would work according to the same principles as those disclosed, namely, by injecting cooled or heated blood into the venous line.

Injecting heated or cooled blood cannot be considered a blood concentration means to provide a specific peak in blood concentration by concentrating the blood as required by feature 1.5. Moreover, as explained above, the second detector in A3, when used, is for calibrating the measurements made (to take into account the influence of the tubing wall on the measurements).

As already explained, the concept of using a blood concentration means is absent from A3, and there is no reason why the provision of a blood concentration means would be obvious because this would mean abandoning the



very idea of that document, which is to inject an additional fluid for the testing. This is precisely what is inventive in the patent in suit, which gets rid of the injection means and uses instead the standard elements of the dialysis machine for creating a peak in the blood concentration in the venous line.

8. Hence, the ground for opposition of lack of inventive step pursuant to Article 100(a) EPC does not prejudice the maintenance of the patent as granted.

### **Order**

### **For these reasons it is decided that:**

The appeal is dismissed.

The Registrar:

The Chairman:



D. Hampe

E. Dufrasne

Decision electronically authenticated