

Internal distribution code:

- (A) [-] Publication in OJ
(B) [-] To Chairmen and Members
(C) [-] To Chairmen
(D) [X] No distribution

**Datasheet for the decision
of 21 May 2019**

Case Number: T 0503/14 - 3.2.02

Application Number: 07733015.7

Publication Number: 2021054

IPC: A61M5/20

Language of the proceedings: EN

Title of invention:

INJECTION DEVICE

Patent Proprietor:

Cilag GmbH International

Opponents:

EIP Limited
DeltaPatents B.V.
Sanofi-Aventis Deutschland GmbH
Ypsomed AG

Headword:

Relevant legal provisions:

EPC Art. 56, 83, 84, 123(2)
RPBA Art. 13(1)

Keyword:

Amendments - extension beyond the content of the application
as filed -main and first auxiliary request (yes),
third auxiliary request (no)
Sufficiency of disclosure - (yes)
Late-filed objection - admitted (no)
Inventive step - third auxiliary request (yes)

Decisions cited:

Catchword:



Beschwerdekammern
Boards of Appeal
Chambres de recours

Boards of Appeal of the
European Patent Office
Richard-Reitzner-Allee 8
85540 Haar
GERMANY
Tel. +49 (0)89 2399-0
Fax +49 (0)89 2399-4465

Case Number: T 0503/14 - 3.2.02

D E C I S I O N
of Technical Board of Appeal 3.2.02
of 21 May 2019

Appellant: Cilag GmbH International
(Patent Proprietor) Gubelstrasse 34
6300 Zug (CH)

Representative: Tunstall, Christopher Stephen
Carpmaels & Ransford LLP
One Southampton Row
London WC1B 5HA (GB)

Appellant: Ypsomed AG
(Opponent 4) Brunnmattstrasse 6
3401 Burgdorf (CH)

Representative: SSM Sandmair
Patentanwälte Rechtsanwalt
Partnerschaft mbB
Joseph-Wild-Straße 20
81829 München (DE)

Party as of right: EIP Limited
(Opponent 1) Fairfax House
15 Fulwood Place
London WC1V 6HU (GB)

Representative: Sharples, Andrew John
EIP
Fairfax House
15 Fulwood Place
London WC1V 6HU (GB)

Party as of right: DeltaPatents B.V.
(Opponent 2) Fellenoord 370
5611 ZL Eindhoven (NL)

Party as of right: Sanofi-Aventis Deutschland GmbH
(Opponent 3) Patent- und Lizenzabteilung
Industriepark Höchst
Geb. K 801
65926 Frankfurt am Main (DE)

Representative: Finger, Catrin
Liedtke & Partner
Patentanwälte
Gerhart-Hauptmann-Strasse 10/11
99096 Erfurt (DE)

Decision under appeal: **Interlocutory decision of the Opposition
Division of the European Patent Office posted on
3 January 2014 concerning the maintenance of
European Patent No. 2021054 in amended form**

Composition of the Board:

Chairman E. Dufrasne
Members: D. Ceccarelli
P. L. P. Weber

Summary of Facts and Submissions

- I. Opponent 4 and the patent proprietor have appealed against the Opposition Division's decision, despatched on 3 January 2014, that, taking into consideration the amendments made by the patent proprietor according to the second auxiliary request, European patent No. 2 021 054 and the invention to which it related met the requirements of the EPC.

The Opposition Division held that the main request contravened Article 123(2) EPC and that the subject-matter of claim 1 of the first auxiliary request lacked an inventive step.

- II. The patent proprietor filed notice of appeal and paid the appeal fee on 13 March 2014. The statement setting out the grounds of appeal was received on 13 May 2014.
- III. Opponent 4 filed notice of appeal and paid the appeal fee on 3 March 2014. The statement setting out the grounds of appeal was received on 13 May 2014.
- IV. The Board summoned the parties to oral proceedings and provided its provisional opinion.
- V. By letter dated 29 January 2019, the party as of right opponent 2 announced that it would not be present at the oral proceedings. By letter dated 9 April 2019, the party as of right opponent 3 also announced that it would not be present at the oral proceedings.
- VI. Oral proceedings took place on 21 May 2019 in the absence of the parties as of right opponents 2 and 3.

The appellant patent proprietor requested that the decision under appeal be set aside and that the patent be maintained on the basis of one of the main, first and third auxiliary requests, filed with letter dated 13 May 2014, fourth and fifth auxiliary requests, filed with letter dated 30 September 2014. The second auxiliary request, filed with letter dated 13 May 2014, was withdrawn.

The appellant opponent 4 requested that the decision under appeal be set aside and that the patent be revoked.

The party as of right opponent 1 requested that the appeal of the patent proprietor be dismissed and that the patent be revoked.

- VII. The party as of right opponent 3 had requested in writing that the appeal of the patent proprietor be dismissed and that the patent be revoked.
- VIII. No requests had been submitted by the party as of right opponent 2.
- IX. The following documents are mentioned in the present decision:
- A1: US-A-3,880,163
A27: US-A-3,702,608
- X. Claim 1 of the **main request** reads as follows:

"An injection device (110) comprising:
a housing (112) adapted to receive a syringe (114) having a discharge nozzle at a first end of the syringe (114), the syringe (114) being movable between a

retracted position in which the discharge nozzle is contained within the housing (112) and an extended position in which the discharge nozzle extends from the housing (112) through an exit aperture (128), wherein the syringe (114) comprises a flange at a second end of the syringe (114) opposite the first end of the syringe (114);

a drive that acts upon the syringe (114) to advance it from its retracted position to its extended position and discharge its contents through the discharge nozzle; and

a syringe carrier (150) for carrying the syringe (114) as it is advanced, the syringe carrier (150) having a first end through which the discharge nozzle extends and a second end opposite the first end,

characterised in that the syringe carrier (150) comprises, at its second end, means for restricting movement of the syringe (114) relative to the syringe carrier (150) in a rearward direction from the first end of the syringe carrier (150) to the second end of the syringe carrier (150) whilst allowing some movement of the syringe in the rearward direction."

Claim 1 of the **first auxiliary request** reads as follows:

"An injection device (110) comprising:

a syringe (114) having a discharge nozzle at a first end of the syringe (114) and a flange at a second end of the syringe (114) opposite the first end of the syringe (114);

a housing (112) adapted to receive the syringe (114), the syringe (114) being movable between a retracted position in which the discharge nozzle is contained within the housing (112) and an extended position in which the discharge nozzle extends from the

housing (112) through an exit aperture (128);

a drive that acts upon the syringe (114) to advance it from its retracted position to its extended position and discharge its contents through the discharge nozzle; and a syringe carrier (150) for carrying the syringe (114) as it is advanced, the syringe carrier (150) having a first end through which the discharge nozzle extends and a second end opposite the first end,

characterised in that the syringe carrier (150) comprises, at its second end, means for restricting movement of the syringe (114) relative to the syringe carrier (150) in a rearward direction from the first end of the syringe carrier (150) to the second end of the syringe carrier (150) whilst allowing some movement of the syringe in the rearward direction."

Claim 1 of the **third auxiliary request**, which corresponds to the second auxiliary request found to meet the requirements of the EPC by the Opposition Division, reads as follows:

"An injection device (110) comprising:

a syringe (114) having a discharge nozzle at a first end of the syringe (114) and a flange at a second end of the syringe (114) opposite the first end of the syringe (114);

a housing (112) adapted to receive the syringe (114), the syringe (114) being movable between a retracted position in which the discharge nozzle is contained within the housing (112) and an extended position in which the discharge nozzle extends from the housing (112) through an exit aperture (128);

a drive that acts upon the syringe (114) to advance it from its retracted position to its extended position and discharge its contents through the

discharge nozzle; and

a syringe carrier (150) for carrying the syringe (114) as it is advanced, the syringe carrier (150) having a first end through which the discharge nozzle extends and a second end opposite the first end,

characterised in that the syringe carrier (150) comprises, at its second end, means for restricting movement of the syringe (114) relative to the syringe carrier (150) in a rearward direction from the first end of the syringe carrier (150) to the second end of the syringe carrier (150) whilst allowing movement of the syringe in the rearward direction;

wherein the means for restricting movement comprises at least one damping element (270) arranged to bias the syringe (114) in a direction from the second end to the first end of the syringe carrier (150), such that movement of the syringe within the syringe carrier in the rearward direction is damped;

wherein the damping element (270) comprises biasing means which is in the form of an arc of resilient material,

wherein each end of the arc is attached to the syringe carrier (150) and an outer convex surface of the arc is in juxtaposition with the flange of the syringe (114)."

Claim 2 of the third auxiliary request reads as follows:

"The injection device (110) of claim 1, wherein the syringe carrier (150) includes a delatch mechanism (250) for releasing the drive from acting on the syringe (114) after the contents of the syringe (114) has been discharged and wherein the damping element (270) is located on the delatch mechanism (250)."

Claim 3 of the third auxiliary request reads as follows:

"The injection device (110) of claim 2, wherein the delatch mechanism (250) is in the form of an annular portion which is adapted to couple with the drive element in order to disconnect the drive element from the drive."

Claim 4 of the third auxiliary request is a further dependent claim.

XI. The arguments of the patent proprietor, where relevant to the present decision, may be summarised as follows:

Main and first auxiliary requests - Added subject-matter

The means for restricting movement of the syringe relative to the syringe carrier in a rearward direction while allowing some movement of the syringe in the rearward direction, as defined in the characterising portion of claim 1 of both the main request and the first auxiliary request, had to be interpreted as excluding a completely free movement of the syringe - by virtue of the means for restricting movement - as well as a complete blockage of the syringe - by virtue of the definition that some movement was allowed. Any movement in a range between those two conditions was permitted.

The exclusion of a completely free movement of the syringe was disclosed in claim 1 of the application as originally filed, which defined the means for restricting movement.

The exclusion of the complete blockage of the syringe was based on a first embodiment according to Figures 3a and 3b and on a second embodiment according to Figures 4a and 4b of the application as originally filed.

In the first embodiment, a nominal separation between restraining lugs and a surface of a syringe flange was disclosed. This nominal separation allowed some movement of the syringe in the rearward direction until the surface of the flange interfaced with a surface of the lugs. Page 8, lines 7 to 16, of the application as originally filed provided a literal basis for the expression "some movement".

In the second embodiment, damping elements were additionally provided to allow some movement of the syringe.

Both the lugs of the first embodiment and the damping elements of the second embodiment provided the restriction of the movement, yet in different ways. The fact that two embodiments disclosed different means for restricting movement while allowing some movement of the syringe within the meaning of the claim implied that those means were not inextricably linked to other features of the individual embodiments. It followed that the general claim definition of those means that allowed some movement of the syringe in the rearward direction was not an impermissible intermediate generalisation and complied with Article 123(2) EPC.

Third auxiliary request - Admissibility of a new objection

Opponent 4 had raised a clarity objection directed to the deletion in claim 1 of the term "some", qualifying

the movement allowed by the means for restricting movement, compared with claim 1 of the main request and the first auxiliary request. Although the third auxiliary request had been on file since the beginning of the appeal proceedings, the objection had only been raised during the oral proceedings. There was no reason for having raised it so late. Moreover, the deletion of the term "some" did not have any impact on the clarity of the claim as the movement allowed was further defined by other claimed features. The objection should not be admitted into the proceedings.

Third auxiliary request - Added subject-matter

In claim 1, the expression "such that the movement of the syringe within the syringe carrier in the rearward direction is damped" was a mere statement of what was already present in claim 7 of the patent as granted. Inherently, a damping element as part of the means for restricting movement, had to damp in that direction. Page 9 of the application as originally filed disclosed damping in the rearward direction within the meaning of the claim. It followed that the expression "such that the movement of the syringe within the syringe carrier in the rearward direction is damped" did not add subject-matter.

Third auxiliary request - Insufficient disclosure

The feature of a "delatch mechanism (250) for releasing the drive from acting on the syringe after the contents of the syringe has been discharged" in claim 2 was sufficiently disclosed in particular on the basis of paragraph [0037] and Figures 4a and 4b of the patent. It would have been within the competence of the person skilled in the art to construct a delatch mechanism as

claimed. Figures 2a and 2b showed a situation before the contents of the syringe had been discharged. The difference in diameter between delatch mechanism 250 and drive sleeve 131 shown in those figures did not preclude the presence of a coupling between the mechanism and the sleeve and was also due to the fact that the figures were schematic.

Figures 4a and 4b of the patent showed a delatch mechanism 250 with an annular portion in accordance with the definition of claim 3. The skilled person would have recognised that that mechanism could be completely annular without changing its function. It followed that the subject-matter of claims 2 and 3 was sufficiently disclosed in the patent.

Third auxiliary request - Inventive step

The subject-matter of claim 1 was inventive over the teaching of A27 and A1.

The injection device according to A27 did not comprise any damping element as defined in claim 1. The provision of such a damping element made it possible to absorb impact forces acting on the injection device when dropped or when subjected to adverse external loading (paragraph [0014] of the patent). The problem solved was to prevent damage to the syringe, in particular to prevent fracturing of the flange (paragraph [0040] of the patent). A1 disclosed a leaf spring for restricting the movement of a syringe within a syringe carrier. The leaf spring of A1, however, did not address the problem solved by the patent. Moreover, such a leaf spring was incompatible with the structure of the device of A27. Hence, the skilled person would

not have considered the combination of A27 with A1.

- XII. The opponents' arguments, where relevant to the present decision, may be summarised as follows:

Main and first auxiliary requests - Added subject-matter

The means for restricting movement of the syringe relative to the syringe carrier in a rearward direction while allowing some movement of the syringe in the rearward direction, as defined in the characterising portion of claim 1 of both the main request and the first auxiliary request, were an impermissible intermediate generalisation of two distinct embodiments of the application as originally filed. According to one embodiment, shown in Figures 3a and 3b, a movement beyond a nominal distance was prevented by the provision of restraining lugs. According to another embodiment, a damping element for damping the movement was provided. The general definition of "some movement" being allowed extended beyond the disclosure of these two embodiments.

Third auxiliary request - Admissibility of a new objection

Opponent 4 objected to the deletion in claim 1 of the term "some", qualifying the movement allowed by the means for restricting movement, as this term had a certain meaning, and its deletion had an influence on the requirements of Article 84 EPC. This objection, raised for the first time during the oral proceedings, was *prima facie* relevant and had to be admitted.

Third auxiliary request - Added subject-matter

In claim 1, the expression "such that the movement of the syringe within the syringe carrier in the rearward direction is damped" had no literal basis in the original application. The general part and the claims of the original application did not disclose a damping element that damped the movement of the syringe in the rearward direction. For example, the damping element could damp a movement transversal to that direction. Hence, a basis could only be provided by the specific embodiment comprising a damping element, i.e. the one shown in Figures 4a and 4b. However, all the features of that embodiment, in particular a hard stop after the damping action, had to be inserted in the claims because they were all essential for damping the movement of the syringe and solving the problem set out in the application as originally filed. Leaving out some of those features amounted to an intermediate generalisation that added subject-matter.

Third auxiliary request - Insufficient disclosure

The feature of a "delatch mechanism (250) for releasing the drive from acting on the syringe after the contents of the syringe has been discharged" in claim 2 was to be considered a mere result to be achieved. According to Figures 2a and 2b and their related description, drive sleeve 131 was released from piston 134, not the syringe. It was not even sufficiently disclosed that such a mechanism could release the drive sleeve from the piston. The figures showed that drive sleeve 131 had a much bigger diameter than mechanism 250. The interaction between those two elements needed to release the drive sleeve from the piston was difficult to figure out. Moreover, the requirement that the drive

be released from acting on the syringe after discharge was impossible to meet as the release had to take place while the piston was still travelling within the syringe barrel in order for the release mechanism to act upon it.

Figures 4a and 4b of the patent did not show any ring or annular portion of a delatch mechanism that could be disconnected from drive sleeve 131. There was no disclosure of such an annular portion in the description either. It followed that the feature of the delatch mechanism 250 being in the form of an annular portion, according to the definition of claim 3, was not sufficiently disclosed.

Third auxiliary request - Inventive step

The only objection of lack of inventive step maintained by opponent 4 was on the basis of the combination of A27 with A1.

Starting from A27, the problem to be solved was how to provide a fit without clearance for the flange of the syringe of A27 and at the same time reduce the production costs of the syringe carrier. This would be achieved by manufacturing the syringe parts of A27 by injection moulding, which would reduce the use of metal parts. More specifically, the skilled person would have turned to A1 and implemented the leaf spring disclosed in that document in the injection device in accordance with A27. Such an implementation required only routine adaptation and was not structurally incompatible with the device of A27.

Reasons for the Decision

1. The appeals are admissible.
2. The invention

The invention relates to an injection device for receiving a syringe and performing an automatic injection through the action of a syringe drive. Such a device can receive a conventional syringe and can be used to extend the syringe needle exposing its needle, discharge the content of the syringe and then automatically retract the needle within the device. Figures 1a and 2b of the patent, reproduced below, show the external appearance and, schematically, the internal components of an injection device in accordance with the invention.

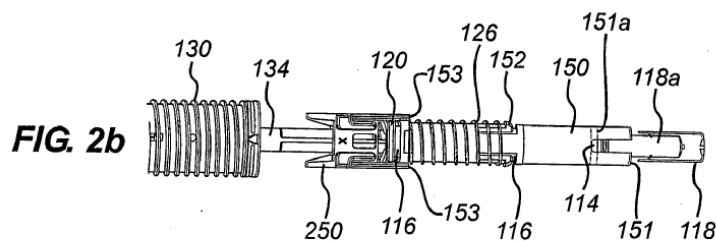
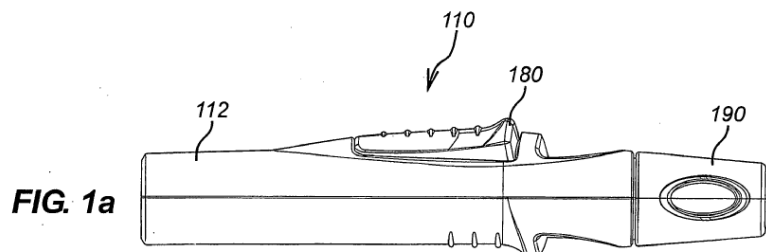

The claimed injection device comprises a housing (112) for receiving the syringe (114), a drive (130) for acting upon the syringe and advancing it from a

retracted position to an extended position, and a syringe carrier (150) having means for restricting movement of the syringe with respect to the syringe carrier in a rearward direction. According to claim 1 of the third auxiliary request, the means for restricting movement comprise a damping element with biasing means in the form of an arc of resilient material having an outer convex surface in juxtaposition with a flange of the syringe.

Figures 4a and 4b of the patent, reproduced below, show such a damping element (270) and its cooperation with the syringe flange (120), for restricting movement of the syringe with respect to the syringe carrier in a rearward direction (R).

FIG. 4a

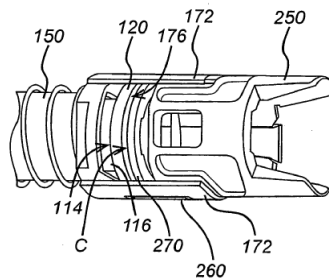
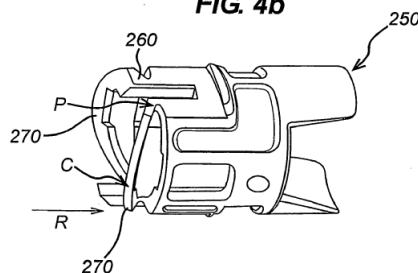

FIG. 4b



The damping element absorbs the shock of an impact force from an end of the injection device (for example, when the syringe is accidentally dropped or simply when the needle of the syringe is inserted into the skin for

injection) such that the force is not instantly transmitted along the syringe, thereby preventing damage to the syringe, in particular to its flange (paragraphs [0014] and [0040] of the patent).

3. Main and first auxiliary requests - Added subject-matter

According to the characterising portion of claim 1 of the main request and the first auxiliary request, the injection device comprises means for restricting the movement of the syringe relative to the syringe carrier in a rearward direction while allowing some movement of the syringe in the rearward direction.

This wording has no basis in the claims or in the general section "SUMMARY OF THE INVENTION" of the application as originally filed. Hence, a basis can only be sought in the description of the preferred embodiments of the invention.

In the application as originally filed, two embodiments with different means for restricting the movement of the syringe relative to the syringe carrier in a rearward direction are disclosed. The second embodiment is depicted in Figures 4a and 4b, reproduced above. The first embodiment is depicted in Figures 3a and 3b, reproduced below.

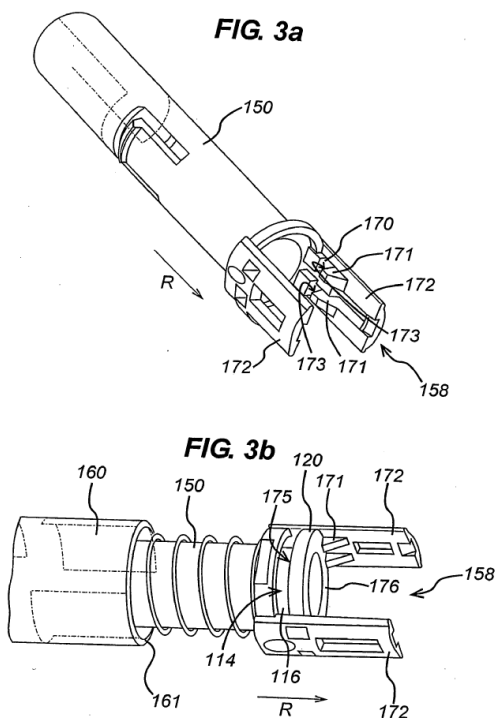

According to the first embodiment, described in particular on page 8, lines 7 to 16, of the application as originally filed, the means for restricting movement are in the form of restraining lugs 171 comprising a restraining surface (173) "to prevent movement in a rearward direction". Furthermore, "there may be a nominal separation between the restraining surface 173 and the upper surface 176 of the flange 120. This nominal separation allows some movement of the syringe 114 in a rearward direction R to buffer the impact of the discharge nozzle as it becomes fully extended during use, thereby reducing pain to a user of the device".

The expression "some movement" in this passage relates to the movement permitted by the nominal separation between the restraining surface and the flange. Hence, rearward movement can only take place over a very short distance, i.e. the nominal separation.

According to the second embodiment, described in particular on page 9, lines 5 to 15, the means for restricting movement are in the form of damping elements 270 that *"can resiliently pivot in a direction R towards the body of the release mechanism 250, providing bias in the opposite direction"*. When damping elements 270 bottom out, reaching the body of release mechanism 250, further movement of the syringe in the rearward direction is prevented. Hence, rearward movement is damped and can take place over a distance up to the bottoming out of the damping elements.

While the Board accepts the proprietor's argument that two distinct ways of restricting movement are disclosed in the two embodiments, in each way the movement allowed is strictly limited and linked to the means for restricting it. Clearly, such a limited movement is also technically linked with the way the injection is performed automatically.

According to claim 1 of the main request and the first auxiliary request, "some movement in the rearward direction" is generally allowed. As the proprietor submitted, this feature merely excludes that the means for restricting movement completely block the syringe in the rearward direction. By omitting the strict limitations on the movement as disclosed in both embodiments of the application as originally filed and defining instead that the movement allowed could be any, somehow restricted, movement, the claims provide the skilled person with the technical information that these strict limitations on the rearward movement are merely optional, in particular, to avoid detachment of the needle shield, which is not derivable from the application as originally filed.

It follows that the main request and the first auxiliary request are not allowable for non-compliance with Article 123(2) EPC.

4. *Third auxiliary request - Admissibility of a new objection*

During oral proceedings, opponent 4 raised a clarity objection under Article 84 EPC directed to the absence in claim 1 of the term "some", qualifying the movement allowed by the means for restricting movement.

This new objection is an amendment to the case of opponent 4, filed after the reply to the statement of grounds of the patent proprietor. Under Article 13(1) RPBA, its admission into the appeal proceedings is at the Board's discretion, which is to be exercised in view of, *inter alia*, the complexity of the new subject-matter submitted, the current state of the proceedings and the need for procedural economy. A further relevant criterion, according to the established case law of the boards of appeal, is the *prima-facie* relevance of the amendment.

The Board notes that the third auxiliary request has been on file since the beginning of the appeal proceedings, and sees no reasons why the objection could only be raised at such a late stage. Moreover, compared with claim 1 of the main request and the first auxiliary request, claim 1 of the third auxiliary request was amended not only by the deletion of the term "some" but also by additions of further structural features such as the damping element with a specific form, contributing to the definition of the movement allowed by the means for restricting the movement of

the syringe in the rearward direction. Opponent 4 did not consider the contribution of the added features. Hence, the *prima facie* relevance of its arguments, solely concerned with the influence on clarity of the deletion, is not given.

Thus, the Board does not admit the new clarity objection into the proceedings under Article 13(1) RPBA.

5. Third auxiliary request - Added subject-matter

Claim 1 of the third auxiliary request is derived from the combination of claims 1, 2, 3, 7, 8 and 10 of the application as originally filed.

Compared with the wording of these original claims, claim 1 also recites that the means for restricting the movement of the syringe relative to the syringe carrier in the rearward direction allow that movement and that the damping element is "such that the movement of the syringe within the syringe carrier in the rearward direction is damped".

However, a damping element inherently damps, but still allows movement. On a technical reading, its definition in claim 1 as part of the means for restricting movement of the syringe relative to the syringe carrier in the rearward direction, which is derived from claim 7 as originally filed, implies that its action is in the direction in which the movement is to be restricted. The embodiment shown in Figures 4a and 4b is in accordance with this technical interpretation. Hence, the argument of opponent 4, that the damping element as originally claimed could damp a movement transversal to the rearward direction, is not accepted,

and the additional wording in claim 1 with respect to the original claims mentioned above is still derived from claim 7 as originally filed.

In conclusion, claim 1 of the third auxiliary request complies with Article 123(2) EPC.

6. Third auxiliary request - Insufficient disclosure

Opponent 4 raised an objection of insufficient disclosure against the feature of the "delatch mechanism (250) for releasing the drive from acting on the syringe after the contents of the syringe has been discharged" in claim 2.

Such a mechanism is described as a "release mechanism" in paragraph [0037] of the patent, in connection with Figures 4a and 4b. It is disclosed that "*the syringe carrier also includes a release mechanism 250 that acts to release the drive sleeve 131 from the piston 134 when the drive sleeve 131 moves over the release mechanism 250 when the syringe 114 reaches its extended position*". Even if the release mechanism is not described in detail, when assessing sufficiency of disclosure, the common general knowledge of the skilled person must also be taken into account. It is the Board's view that, based on the common general knowledge, the design of a suitable coupling between drive sleeve 131 and piston 134 which can be released by interaction with the two protrusions of release mechanism 250 in Figures 4a and 4b would have been within the competence of the skilled person. Releasing drive sleeve 131 from piston 134 implies that the drive sleeve is also released from the syringe to which piston 134 belongs. Whether the figures show drive sleeve 131 with a bigger diameter than mechanism 250 is

of little relevance as a suitable coupling could be provided within the drive sleeve. Furthermore, providing a coupling which is acted upon at the end of the travel of the piston within the syringe, and eventually released at the very end of that travel, would have been a clear matter of design for the skilled person.

Opponent 4 raised a further objection against the feature of the delatch mechanism (250) being "in the form of an annular portion" in claim 3.

However, release mechanism 250 is depicted with a globally annular shape in Figures 4a and 4b. Hence, these figures provide sufficient disclosure of the subject-matter of claim 3 when read in the context of the patent.

In conclusion, the third auxiliary request complies with Article 83 EPC.

7. Third auxiliary request - Inventive step

Opponent 4 argued that the subject-matter of claim 1 was not inventive starting from A27 in combination with A1.

A27, Figures 1, 3 and 8 of which are reproduced below, discloses an injection device comprising a syringe (50), a housing (10) adapted to receive the syringe, a drive (springs 78 and 110) and a syringe carrier (holder 62). The syringe carrier has an end (where resilient members 72 are placed, Figure 3) through which the syringe extends and a second opposite end where means for restricting the movement of the syringe with respect to the syringe carrier, in the form of

slots 70 (Figure 3), are present.

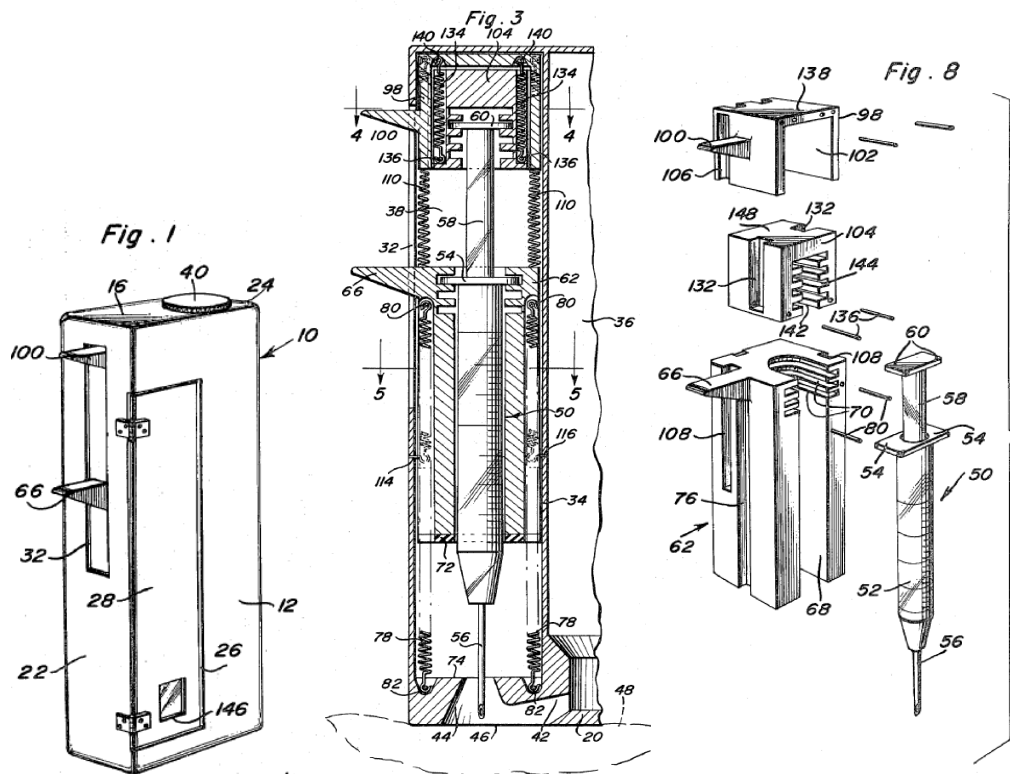

Slots 70 do not provide any damping effect. Hence A27 does not disclose a damping element as defined in claim 1.

According to the patent, the provision of a damping element, in particular its configuration in the form of an arc with an outer convex surface in juxtaposition with the syringe flange as defined in claim 1 makes it possible to absorb impact forces acting on the injection device or sudden syringe movements when the device is dropped or subjected to adverse external loading (paragraphs [0014] and [0040] of the patent).

The objective technical problem solved is therefore how to prevent damage to the syringe, in particular fracturing of the flange.

The problem formulated by opponent 4, i.e. to provide a fit without clearance for the flange of the syringe and at the same time reduce the costs of the syringe carrier, is not accepted by the Board as it is neither mentioned nor derivable from the patent. Moreover, it is not apparent how the provision of a further damping element in an existing device may contribute to the reduction of costs.

A1, referred to by opponent 4, discloses an injection device. As visible in Figure 4 reproduced below, the injection device comprises a syringe (11A), a housing (22) adapted to receive the syringe, a drive (plunger actuator 41) and a syringe carrier (21). The syringe carrier has an end (49), through which the syringe extends, and a second opposite end. The syringe carrier also comprises means for restricting the movement of the syringe with respect to the syringe carrier in the form of a leaf spring (spring 57, the function of which is explained in column 4, lines 5 to 9).

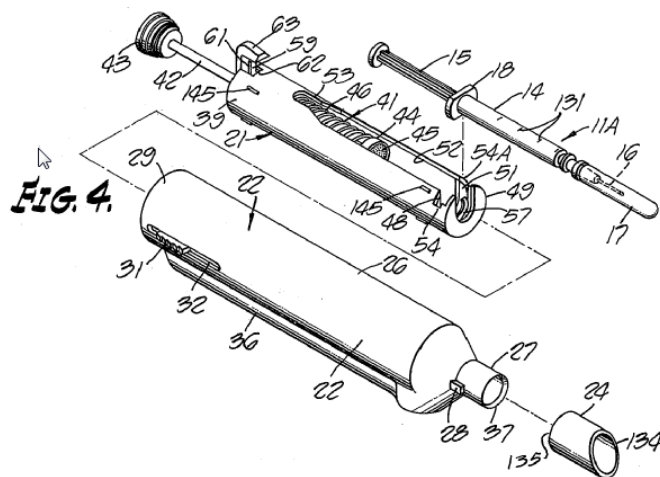

Opponent 4 argued that the skilled person would have implemented the leaf spring of A1 in the injection device in accordance with A27. However, A1 does not

address the objective technical problem mentioned above. Quite on the contrary, according to A1, leaf spring 57 ensures a snug fit of flange 18 of syringe 11A in receptacle 48 of the syringe carrier (column 6, line 8). Hence, no damping action of that spring is taught by A1. As a consequence, there is no reason why the skilled person would have turned to A1 when faced with the objective technical problem.

It follows that the subject-matter of claim 1 of the third auxiliary request is inventive (Article 56 EPC) over A27 in combination with A1.

8. Opponents 1 to 3 are not appellants. Hence, there is no need for the Board to consider further objections raised by them against the third auxiliary request, which was considered to meet the requirements of the EPC by the Opposition Division in the impugned decision.

Order

For these reasons it is decided that:

The appeals are dismissed.

The Registrar:

The Chairman:



D. Hampe

E. Dufrasne

Decision electronically authenticated