

**Internal distribution code:**

- (A) [ - ] Publication in OJ
- (B) [ - ] To Chairmen and Members
- (C) [ - ] To Chairmen
- (D) [ X ] No distribution

**Datasheet for the decision  
of 24 April 2018**

**Case Number:** T 2332/15 - 3.2.03

**Application Number:** 05734048.1

**Publication Number:** 1733096

**IPC:** E01B29/17

**Language of the proceedings:** EN

**Title of invention:**

RAILWAY RAIL HANDLING APPARATUS AND METHOD

**Patent Proprietor:**

W & D McCulloch Ltd.

**Opponent:**

QTS Limited

**Headword:**

**Relevant legal provisions:**

EPC Art. 100(a), 54(1), 56, 123(2), 114(2)  
RPBA Art. 12(4), 13(1)

**Keyword:**

Novelty - main request (no) - auxiliary request (yes)  
Late-filed auxiliary request - admitted (no)  
Amendments - added subject-matter (no)  
Inventive step - auxiliary request (yes)

**Decisions cited:**

T 0351/12, T 0453/12

**Catchword:**



**Beschwerdekammern**  
**Boards of Appeal**  
**Chambres de recours**

Boards of Appeal of the  
European Patent Office  
Richard-Reitzner-Allee 8  
85540 Haar  
GERMANY  
Tel. +49 (0)89 2399-0  
Fax +49 (0)89 2399-4465

Case Number: T 2332/15 - 3.2.03

**D E C I S I O N**  
**of Technical Board of Appeal 3.2.03**  
**of 24 April 2018**

**Appellant:** W & D McCulloch Ltd.  
(Patent Proprietor) Craigmains  
10A Main Street  
Ballantrae, Ayrshire KA26 0NB (GB)

**Representative:** Murgitroyd & Company  
Scotland House  
165-169 Scotland Street  
Glasgow G5 8PL (GB)

**Appellant:** QTS Limited  
(Opponent) Rench Farm  
Drumclog  
Strathaven  
ML10 6QJ (GB)

**Representative:** HGF Limited  
Delta House  
50 West Nile Street  
Glasgow G1 2NP (GB)

**Decision under appeal:** **Interlocutory decision of the Opposition**  
**Division of the European Patent Office posted on**  
**19 October 2015 concerning maintenance of the**  
**European Patent No. 1733096 in amended form.**

**Composition of the Board:**

**Chairman** G. Ashley  
**Members:** V. Bouyssy  
D. Prietzel-Funk

## **Summary of Facts and Submissions**

- I. European patent No. 1 733 096 (in the following: "the patent") relates to an apparatus and a method for handling a railway rail.
- II. The patent as a whole was opposed on the grounds of unallowable extension of the content of the application as filed (Article 100(c) EPC), lack of novelty and lack of inventive step (Article 100(a) EPC).
- III. At oral proceedings on 25 January 2012, the opposition division decided that the ground of opposition under Article 100(c) EPC prejudiced the maintenance of the patent as granted and that the auxiliary requests filed before it contravened Article 123 EPC.
- IV. This decision was appealed by the patent proprietor.
- V. In decision T 453/12 of 14 October 2014, the Board (in a different composition) concluded that the granted claims did not amount to an unallowable extension of the subject-matter, and hence set aside the decision under appeal and remitted the case to the opposition division for further prosecution, in particular for consideration of the objections under Article 100(a) EPC.
- VI. At oral proceedings on 1 September 2015, the opposition division decided that the subject-matter of claim 1 as granted lacked novelty. It refused to admit into the proceedings auxiliary requests 1 and 2 as filed during the oral proceedings and decided that the subject-matter of claim 1 according to auxiliary request 3 before it lacked inventive step, but that the patent as

amended on the basis of auxiliary request 4 before it met the requirements of the EPC.

- VII. This intermediate decision was appealed by both the patent proprietor and the opponent and is the subject of the present proceedings.
- VIII. As both parties are thus appellant and respondent, for the sake of simplicity they are referred to as patent proprietor and opponent.
- IX. With the summons to oral proceedings, the Board sent a communication pursuant to Article 15(1) of the Rules of Procedure of the Boards of Appeal (RPBA) indicating its preliminary opinion of the case.
- X. Oral proceedings before the Board were held on 24 April 2018.
- XI. Final requests

The patent proprietor requested that the appealed decision be set aside and the patent be maintained as granted (main request), alternatively as amended on the basis of one of auxiliary requests 1, 2, 3, 4a, 4b, 5, 6, 7 to 8, filed with letter dated 20 February 2018 (auxiliary requests 1, 2, 4a and 4b), letter dated 25 February 2016 (auxiliary requests 3, 5 and 6) and letter dated 11 July 2016 (auxiliary requests 7 and 8).

The opponent requested that the appealed decision be set aside and the patent be revoked in its entirety.

- XII. Claims of the patent proprietor's main request and auxiliary requests 1 and 2

(a) Main request

Independent apparatus claim 1 as granted is directed to the following subject-matter (compared with claim 1 of the application as originally filed, added passages are indicated in bold, deleted passages in strike-through; the feature numbering has been introduced by the patent proprietor and used by both parties):

- 1.1 Railway rail handling apparatus **(10)** configured for track side operation comprising
- 1.2 ground engaging wheel means **(28)** and
- 1.3 rail moving means **(12)**, which is configured to engage a railway rail **(80)** along part of its length,
- 1.4 the rail moving means **(12)** being further configured for its progressive movement longitudinally along the rail **(80)** as the railway rail handling apparatus **(10)** moves on the ground engaging wheel means **(28)** and, as the rail moving means **(12)** so moves, for progressive bending of the rail **(80)** laterally of an unbent part of the rail to thereby move the rail **(80)** from a first position to a second position,
- 1.5 **characterised in that** ~~the railway rail handling apparatus defining a footprint over the ground,~~ and the rail moving means **(12)** ~~being~~ **is**, in use, operative within the footprint **of the apparatus on the ground,**
- 1.6 **to reduce imbalances in the railway rail handling apparatus (10) that may be caused by forces exerted in handling a rail,**
- 1.7 **the footprint being defined by the ground engaging wheel means (28)."**

Independent method claim 28 as granted is directed to the following subject-matter (compared with method claim 32 as originally filed, added passages are indicated in bold, deleted passages in strike-through):

A method of handling a railway rail (80) by means of a railway rail handling apparatus (10), which is configured for track side operation and comprises ground engaging wheel means (28), the method comprising: engaging a railway rail (80) along part of its length by a rail moving means (12) of the railway rail handling apparatus (10), and moving the railway rail handling apparatus on the ground engaging wheel means (28) to progressively move the rail moving means (12) longitudinally along the rail (80) to progressively bend the rail (80) laterally of an unbent part of the rail (80) to thereby move the rail (80) from a first position to a second position, ~~in which~~ **characterised in that** the rail moving means (12) is operated within a footprint ~~over the ground of the railway rail handling apparatus~~ **on the ground of the ground engaging wheel means (28), to reduce imbalances in the railway rail handling apparatus (10) that may be caused by forces exerted in handling a rail.**

(b) Auxiliary request 1

Claim 1 differs from claim 1 of the main request in that it comprises the additional limitation that "all the rail moving means (12) configured for progressive bending of the rail (80) laterally is, in use, operative within the footprint of the apparatus on the ground".

(c) Auxiliary request 2

Claim 1 differs from claim 1 of the main request in that it comprises the additional limitation that "the railway handling apparatus has no rail moving means (12) which is, in use, operative outside the footprint of the apparatus on the ground".

Dependent claim 5 differs from claim 5 of the main request in that it has been amended to refer to "two spaced apart support members", instead of "a plurality of spaced apart support members".

Claim 28 differs from claim 28 of the main request in that it comprises the additional feature that "no rail moving means (12) is operated outside the footprint of the apparatus on the ground".

XIII. Cited evidence

In their statements setting out the grounds of appeal, the parties referred among others to the following prior art documents, which were filed in the opposition proceedings and are cited in the decision under appeal:

D1: US 3,754,505;  
D3: EP 0 084 298 A1

XIV. The arguments of the parties, insofar as relevant for the present decision, can be summarised as follows:

(a) Main request - Novelty

The patent proprietor submitted that the opposition division erred in deciding that the railway rail handling apparatus disclosed in D1 anticipated the



subject-matter of claim 1. In fact, D1 failed to disclose the features of claim 1 that the rail moving means is configured, as the apparatus moves along a rail, "for progressive bending of the rail laterally of an unbent part of the rail to thereby move the rail from a first position to a second position" (see second part of feature 1.4) and "is, in use, operative within the footprint of the apparatus on the ground" (see feature 1.5). Contrary to the opposition division's view, there was no disclosure in D1 that the rear tongs 20 shown in Figure 1 were adapted to bend the rails 4 on their own. In fact, they relied on the front tongs 19 to provide the reaction force necessary to induce bending of the rails, and the front tongs 19 were not operative within the footprint defined by the vehicle tires 3 on the ground, contrary to the requirement of claim 1. Besides, it would be impossible to use the tongs 20 alone to bend a single rail at a time, because they were suspended on chains 21 and thus they would swing laterally and interfere with the tires 3 and so prevent the vehicle from being moved.

The opponent argued that the rear tongs 20 - as well as the rear rollers 15 - disclosed in Figure 1 of D1 constituted rail moving means as defined in claim 1. The claim was not limited to the rail moving means being configured to induce bending of a rail on its own. The claim wording did not exclude that the apparatus comprised further rail moving means being, in use, operative outside the footprint of the apparatus on the ground. At any rate, the rear tongs 20 could be used alone, i.e. without the front tongs 19, to bend progressively a single rail laterally, even though such a use was not mentioned in D1.

(b) Auxiliary request 1 - Admission in the appeal proceedings

The opponent requested the Board not to admit auxiliary request 1 into the proceedings because it was filed at a very late stage and was not clearly allowable. In fact, the amendment raised new objections under Article 123(2) EPC not yet discussed and claim 1 as amended did not overcome the objection of lack of novelty in light of D1, as set out with regard to claim 1 of the main request.

The patent proprietor argued that auxiliary request 1 was filed in direct reaction to the Board's preliminary opinion in its communication under Article 15(1) RPBA that auxiliary request 1 filed with the statement of grounds of appeal contravened Article 123(2) EPC. The feature added to claim 1 made clear that - in contrast to the rail moving means disclosed in D1 - the rail moving means of the invention was operative only within the footprint of the apparatus on the ground, and that the apparatus comprised no rail moving means which was operative outside the footprint.

(c) Auxiliary request 2 - Article 123(2) EPC

The patent proprietor submitted that, contrary to the opposition division's view, the added disclaimer that "the railway handling apparatus has no rail moving means which is, in use, operative outside the footprint of the apparatus on the ground" was directly and unambiguously derivable from the application documents as originally filed, in particular from the general teaching in the paragraph bridging pages 2 and 3 of the description and from the drawings.

The opponent argued that neither the teaching in the paragraph bridging pages 2 and 3 nor the schematic drawings provided a solid basis for the disclaimer.

(d) Auxiliary request 2 - Novelty

The patent proprietor argued that D1 failed to disclose the added feature that "the railway handling apparatus has no rail moving means which is, in use, operative outside the footprint of the apparatus on the ground". In fact, the apparatus disclosed in Figure 1 of D1 comprised rail moving means in the form of front rollers 14 and tongs 19, which were operative outside the footprint defined by the tires 3.

The opponent argued that the added feature could not distinguish the claimed apparatus from that disclosed in D1. The front rollers 14 and tongs 19 disclosed in Figure 1 of D1 did not form rail moving means in the sense of claim 1. They served as raising and supporting means for the old and new rails, but they had no guiding function and thus played no role in the progressive bending of the old and new rails.

(e) Auxiliary request 2 - Inventive step

The opponent submitted that the feature added to claim 1 could not provide for an inventive step over D1. The technical problem objectively solved by this feature was how to improve the apparatus' stability during operation. The skilled person faced with this problem and assisted by his common general knowledge, would inevitably displace the front rollers 14 and tongs 20, alternatively widen the footprint of the vehicle on the ground, to such extent that rollers 14 and tongs 20

would be operative only within the footprint in use. In doing so he would arrive at the claimed solution.

The patent proprietor argued that the subject-matter of claim 1 involved an inventive step over D1. The claimed solution to the objective problem was not rendered obvious by common general knowledge. D1 taught that the rollers 14 and 15 and the tongs 19 and 20 were arranged in the smallest possible space to enable the continuous replacement of pairs of old and new rails (column 2, lines 5 to 9), and this would deter the skilled person from displacing front rollers 14 and tongs 19 towards rear rollers 15 and tongs 20. Even if the skilled person were to consider widening the footprint of the vehicle disclosed in D1 to improve its stability, he would have no motivation to widen it to such extent that all the rail moving means would be, in use, operative within the footprint. In fact, he would be more inclined to use a counterweight to neutralise the weight of the crane boom 2 and that of the old and new rails.

## **Reasons for the Decision**

### 1. Main request - Novelty

1.1 D1 discloses, in Figure 1, an apparatus for continuously replacing an old pair of rails by a new pair of rails on a tie bed or foundation (column 1, lines 4 to 11). The illustrated apparatus includes a rubber-tired vehicle 1 bridging or spanning the railway track. New rails are picked up at the front of the vehicle and laid at the correct gauge; old rails are lifted from the track bed also at the front of the vehicle, then passed after the vehicle before being deposited on the track bed to the rear of the vehicle,

within the gauge of the newly laid rails. The vehicle is equipped at its front end and in the region of the vehicle frame as well as at its rear end, with roller and guiding elements for raising the old rails 4, passing them beneath the vehicle and moving them inwardly to a smaller gauge of railway; at its front end and underneath the vehicle frame, the vehicle has further roller and guiding elements for raising the new rails 5, passing them beneath the vehicle and moving them outwardly to the correct gauge of railway (see column 1, line 50 to column 2, line 3; column 3, line 53 to column 4, line 24; method claim 1; and apparatus claim 3). Thus, in use, the old rails intersect the path of curvation of the new rails within the extent of the vehicle (column 2, lines 3 to 5).

- 1.2 In the illustrated apparatus, the roller and guiding elements for the old rails 4 are in the form of a pair of front rollers 14 and a pair of rear rollers 15, each being rigidly attached to the vehicle frame (column 2, line 28 to column 3, line 4 and Figures 1, 2 and 4). The roller and guiding elements for the new rails 5 are in the form of a pair of front tongs 19 and a pair of rear tongs 20, each including a pair of lugs 23 with rollers 24 attached to their ends and being suspended from a crane boom 2 and the vehicle frame, respectively (column 3, lines 5 to 52 and Figures 1 and 2). The rear rollers 15 are appropriately spaced from each other to deposit the old rails 4 at the rear end of the vehicle, within the newly laid rails. The correct gauge of railway between the new rails 5 is guaranteed by adjusting the width of the rear tongs 20 by means of a tie rod.
- 1.3 In the light of this teaching of D1 and of common general knowledge, a skilled reader immediately

understands that, as the vehicle 1 moves along the railway, the old rails 4 are progressively bent outwardly by means of front and rear rollers 14 and 15, while the new rails 5 are progressively bent inwardly by means of front and rear tongs 19 and 20. This understanding is illustrated in an annotated copy of Figure 1 of D1, which has been filed by the patent proprietor (letter dated 20 February 2018) and was referred to by both parties. It is reproduced hereafter.

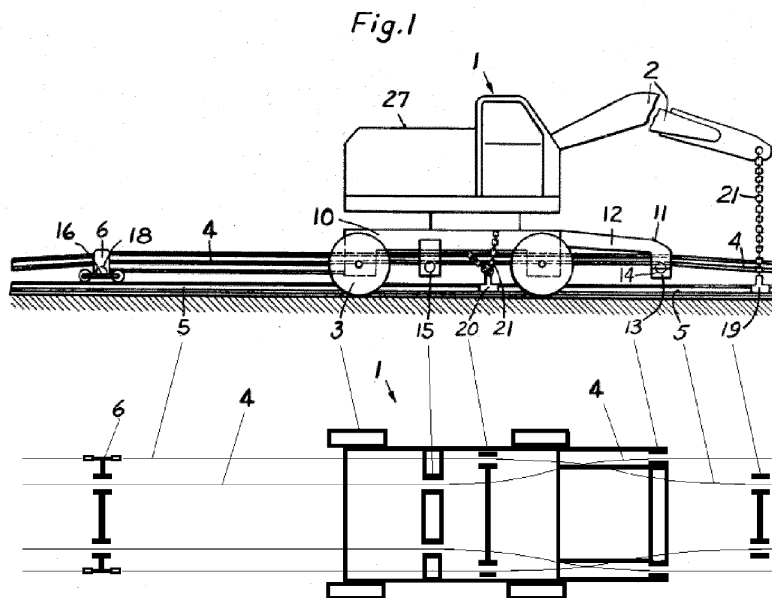

- 1.4 In the oral proceedings, the patent proprietor submitted that, although the illustration is derived from D1, it does correctly reflect the technical teaching with regard to the rollers 14 and 15 and the tongs 19 and 20.
  
- 1.5 The Board shares the patent proprietor's view insofar that it is not expressly required in D1 that the spacing of the front rollers 14 must correspond to the correct gauge of railway. At any rate, it is clear that the spacing of the front rollers 14 must be larger than

that of the rear rollers 15 since D1 teaches that the rollers 14 force the old rails 4 to move inwardly as the vehicle moves.

1.6 On the other hand, the Board is not persuaded by the patent proprietor's contention that, at variance with the above illustration, the old rails 4 might pass along both sides of the vehicle, outside of the footprint defined by the vehicle tires 3, and that the rear rollers 15 might be operative outside the footprint. In support of its contention, the patent proprietor referred to the side view of the apparatus in Figure 2 of D1 and to text passages of the description of D1, on column 1, lines 52 and 53 ("such rails are moved past both sides of the vehicle frame"), on column 2, lines 41 to 44 ("the old rails 4 ... are moved laterally along and past the vehicle frame 10") and on column 3, lines 58 and 59 ("passing them along both sides of the vehicle"). However, Figure 2 and these passages must be read in context of the teaching of D1, and it is clear to the skilled reader that the rear rollers 15 serve to bend progressively the old rails, and thus must be operative within the footprint defined by the tires 3. Indeed, D1 consistently teaches that the width between the tires 3 is large enough for the vehicle to straddle the old and new rails (column 2, lines 23 to 27; column 3, lines 53 to 55; method claim 1; apparatus claim 3) and that, as the vehicle moves along the railway, the old rails intersect the path of curvation of the new rails within the footprint (column 1, lines 60 to 62; column 2, lines 3 to 5).

1.7 The Board is also not persuaded by the patent proprietor's argument that, at variance with the above illustration, the new rails 5 are not progressively curved or bent between the tongs 19 and 20 because

their spacing is the same or similar. It is consistently taught in D1 that the new rails 5 are moved outwardly from their initial location within the track to the correct gauge of railway by means of the tongs 19 and 20, and that this is achieved by spreading the lugs (column 1, lines 63 to column 2, line 1; column 3, lines 18 to 20 and 40 to 52; column 4, lines 9 to 17; apparatus claim 5). It follows from the teaching on column 3, lines 8 to 11, 18 to 20 and 34 to 39 that the rollers of the tongs 19, and those of the tongs 20, are appropriately spaced from each other by means of a tie rod, but not that the tongs 19 and 20 have the same or similar spacing.

1.8 The opponent disputes that the front rollers 14 and tongs 19 shown in Figure 1 of D1 have any guiding function in addition to raising and supporting the rails, and that they do not play any role in the lateral bending of the old and new rails. The Board is not convinced. Firstly, the guiding function of the front rollers 14 is expressly mentioned in D1, at column 3, lines 55 to 57 ("roller and guiding elements") and at column 4, lines 4 and 5 ("front guiding rollers"), while that of the front tongs 19 is mentioned at column 4, lines 9 to 11 ("roller and guiding elements for guiding the new rails"). Secondly, the guiding function of the front rollers 14 and tongs 19 - as well as that of the rear rollers 15 and tongs 20 - is essential for providing the lateral force necessary to induce the progressive bending of the old and new rails as the vehicle moves along the railway.

1.9 Thus from the above discussion of Figure 1 of D1, in the terms of claim 1, the illustrated apparatus forms a railway rail handling apparatus 1 configured for track side operation, comprising:



- ground engaging wheel means (tires 3);
- rail moving means (rear rollers 15 or tongs 20), which is configured to engage a railway rail (old rail 4 and new rail 5, respectively) along part of its length,
- the rail moving means (15; 20) being further configured for its progressive movement longitudinally along the rail (4; 5) as the railway rail handling apparatus (1) moves on the ground engaging wheel means (3),
- the rail moving means (15; 20) being, in use, operative within the footprint of the apparatus (1) on the ground,
- to reduce imbalances in the railway rail handling apparatus (1) that may be caused by forces exerted in handling a rail,
- the footprint being defined by the ground engaging wheel means (3).

1.10 The parties further dispute whether D1 discloses the feature of claim 1 that the rail moving means is configured, as it so moves, "for progressive bending of the rail laterally of an unbent part of the rail to thereby move the rail from a first position to a second position" (see second part of feature 1.4 of claim 1).

1.11 The Board shares the opponent's view that this feature cannot distinguish the claimed apparatus from that disclosed in D1. Indeed, it is apparent that the rear rollers 15 and tongs 20 in Figure 1 of D1 are respectively configured for progressive bending of the old and new rails laterally, as the apparatus 1 progresses along the rails, moving the old rails 4 inwardly and the new rails 5 outwardly.

- 1.12 The patent proprietor submits that the disputed feature is not disclosed in D1 because, in contrast to the rail moving means of the invention, neither the rear rollers 15 nor the rear tongs 20 can by themselves progressively bend an unbent part of a rail within the footprint of the apparatus on the ground. The Board is not convinced for the following reasons:
- 1.12.1 The alleged difference between the rail moving means of claim 1 and those disclosed in D1 is not reflected by the wording of claim 1. In fact, the claim is not limited to the rail moving means adapted to bend the rail on its own. This understanding is confirmed by the teaching in the patent. In Figure 4, it is apparent that bending of the rail 80 is induced by the lateral force exerted by the rail moving means 12 on the rail and the reaction force due to the friction between the unraised part of the rail and the ground, outside of the footprint. Thus, the claim wording does not exclude that the rail moving means interacts with further means, operative outside the footprint, to achieve the required progressive bending of the rail, as is the case in D1 (see front rollers 14 and tongs 20 respectively).
- 1.12.2 Notwithstanding the above, the apparatus disclosed in D1 could be used to move apart two rails by using the rear tongs 20 alone, i.e. without the front tongs 19, even though such an operation is not mentioned in D1. When doing so the tongs 20 would progressively bend the rails laterally as the vehicle moves, in the manner described in D1. The reaction force necessary for bending each rail would then be provided by the friction between the unraised part of the rail and the ground, as in the illustrated embodiment of the invention. The patent proprietor contends that it would

be impossible to use the rear tongs 20 for bending a single rail at a time. However, claim 1 is not limited to the rail moving means being adapted to bend a single rail at a time. In fact, this subject-matter is defined in dependent claim 4.

1.12.3 Finally, the wording of claim 1 is neither limited to the bending of the rail occurring only within the footprint of the apparatus, nor to the rail remaining unbent until it is brought into engagement with the rail moving means. In fact, it is taught in paragraphs 11, 15 and 24 of the patent specification that the rail end needs to be bent to some extent before it is brought into engagement with the rail moving means. Thus, in the context of claim 1, the term "an unbent part of the rail" can be construed as further defining the term "progressive bending of the rail laterally".

1.13 The Board shares the patent proprietor's view that the front rollers 14 and tongs 19 constitute further rail moving means for progressive bending of a rail laterally. Indeed, they respectively interact with the rear rollers 15 and tongs 20 to bend progressively the old and new rails laterally. In addition, it is apparent that the tongs 19 could be used alone to move and thereby progressively bend two rails laterally, in the same manner as set out above with regard to the rear tongs 20 (see point 1.12.2).

1.14 However, contrary to the patent proprietor's view, the provision of such further rail moving means is not excluded by the wording of claim 1. In fact, it is neither expressly nor implicitly required in the claim that the railway handling apparatus has no rail moving means which is, in use, operative outside the footprint of the apparatus on the ground. The scope of claim 1 is

not limited to the specific apparatus comprising a single rail moving means, as shown in the drawings of the patent.

- 1.15 Hence, the Board agrees with the opposition division that the subject-matter of claim 1 as granted lacks novelty in light of D1.
2. Auxiliary request 1 - Admission in the appeal proceedings
  - 2.1 Under Article 13(1) RPBA any amendment to a party's submissions after it has filed its statement of grounds of appeal or reply may be admitted and considered at the Board's discretion. It is established case law that amended claims belatedly filed at such a stage must be clearly allowable in order to be admitted into the proceedings. Hence, it must be immediately apparent to the Board, with little investigative effort on its part, that the amendments made successfully overcome all outstanding objections under the EPC, without giving rise to new ones.
  - 2.2 The patent proprietor filed auxiliary request 1 with letter dated 20 February 2018, allegedly in reaction to the Board's communication under Article 15(1) RPBA in preparation of the oral proceedings.
  - 2.3 The Board exercised its discretion not to admit this request into the proceedings for the following reasons (Article 13(1) RPBA):
  - 2.4 Claim 1 of new auxiliary request 1 differs from claim 1 of auxiliary request 1 filed with the statement setting out the grounds of appeal in that the disclaimer that "the railway handling apparatus has no rail moving

means which is, in use, operative outside the footprint of the apparatus on the ground" has been replaced by the positive feature that "all the rail moving means configured for progressive bending of the rail laterally is, in use, operative within the footprint of the apparatus on the ground".

2.5 Claim 1 as now amended would nevertheless still lack novelty in view of D1, for the reasons set out above with regard to claim 1 of the main request. The Board agrees with the opponent that the added feature could be construed in the sense that all of a given rail moving means is, in use, operative within the footprint of the apparatus on the ground. This requirement appears to be met by the rear rollers 15 as well as the rear tongs 20 as disclosed in D1, which both form rail moving means configured for progressive bending of the rail laterally (see points 1.11 and 1.12 above), and which are located within the footprint of the apparatus.

3. Auxiliary request 2 - Admission in the appeal proceedings

3.1 Auxiliary request 2 is identical to auxiliary request 1 filed with the patent proprietor's statement of grounds of appeal (letter dated 25 February 2016), and to auxiliary request 2 which was filed in the oral proceedings before the opposition division but not admitted.

3.2 The opponent has not indicated, and the Board cannot find, any reason why this request should be disregarded (Article 114(2) EPC and Article 12(4) RPBA). According to the decision under appeal (see point 16 of the reasons), the opposition division decided not to admit

auxiliary request 2 into the proceedings because it *prima facie* failed to meet the requirements of Article 123(2) EPC. Thus, the opposition division had exercised its discretionary power under Article 114(2) EPC by taking into account the right principles and the Board has no reason to overturn this discretionary decision. At the appeal stage, the admissibility of this request is now governed by Article 12(4) RPBA. This does not exclude the admissibility of a request not admitted at first instance by a correct discretionary decision. The Board has to exercise its own discretion under Article 12(4) RPBA independently, giving due consideration to the appellant's submissions. In the present case, re-filing the request with the statement of grounds of appeal and at the same time challenging the opposition division's substantive assessment of Article 123(2) EPC, which was instrumental in deciding not to admit the request, is seen to be an appropriate reaction to developments in the last phase of the opposition proceedings and to the appealed decision (see e.g. T 351/12, point 2 of the reasons). In addition, the arguments of the appellant with regard to Article 123(2) EPC are *prima facie* persuasive. Thus, auxiliary request 2 is admitted into the proceedings.

4. Auxiliary request 2 - Articles 123 and 84 EPC
- 4.1 Claim 1 as amended differs from claim 1 as granted by the added limitation that "the railway rail handling apparatus has no rail moving means which is, in use, operative outside the footprint of the apparatus on the ground". Method claim 28 has been amended accordingly (see added wording "wherein no rail moving means (12) is operated outside the footprint of the apparatus on the ground").

- 4.2 Contrary to the opposition division's view, these amendments are supported by the information in the application documents as originally filed.
- 4.3 The application as filed is concerned with mobile railway rail handling equipment with ground and/or rail engaging wheels for handling rails in maintenance operations, in particular for lifting worn rails and laying replacement rails, such as a road-rail plant/crane (see the application, page 1, paragraphs 2 and 4; page 2, paragraphs 2 and 3; page 3, lines 28 to 31).
- 4.4 On page 1, lines 15 to 24 and page 2, lines 23 to 32, reference is made to a road-rail plant/crane of the prior art, provided with both ground engaging wheels and railway engaging wheels, which makes use of an extendible boom to grab, raise and move rails, and which is usually provided with a counterbalance to neutralise the weight of the boom and the rail being moved.
- 4.5 The reader is taught in the paragraph bridging pages 1 and 2 that the railway rail handling apparatus according to the invention has been devised to overcome the shortcomings of this known road-rail crane, ensuring that "the railway rail handling apparatus (defines) a footprint over the ground, and the rail moving means (is), in use, operative within the footprint" (see page 2, lines 7 to 8).
- 4.6 In the paragraph bridging pages 2 and 3, it is stated that "operation of the rail moving means within the footprint of the rail handling apparatus can provide for advantages over conventional approaches" and that "operation within the footprint according to the present invention reduces imbalances in the railway

rail handling apparatus that may be caused by forces exerted in handling a rail, whereby the need for a counterbalance is at least reduced".

4.7 In the light of this teaching and of common general knowledge, the skilled reader immediately understands that, according to the invention, the rail moving means configured for progressive bending of the rail laterally must be operative above a point within the apparatus's footprint, i.e. the area bounded by its ground engaging wheel means on the ground, so that the forces exerted on the rail moving means during bending of a rail as well as the rail weight are safely transmitted to the ground engaging wheel means, thereby overcoming the problem of imbalance experienced with the road-rail crane of the prior art (see T 453/12, point 1.10 of the reasons). In other words, the apparatus comprises no rail moving means configured for progressive bending of the rail laterally which are operative outside the footprint, as otherwise the object pursued in D1 would not be attained.

4.8 This understanding is confirmed by the preferred embodiments as disclosed in the description and illustrated in the drawings. Figures 1a, 1b, 3a, 3b, 4, 5a and 5b show such a preferred railway rail handling apparatus 10, which comprises a single rail moving means 12 configured for progressive bending of the rail laterally, which is, in use, operative within the footprint of the apparatus on the ground. There is no mention or suggestion of a further rail moving means being operative outside the footprint, let alone of the apparatus comprising a further rail moving means. It is stated on page 7, lines 28 to 32 that the railway rail handling apparatus may further comprise rail raising means. However, such rail raising means is used to help



lift an end of a rail towards the rail moving means before the operation commences, and thus is not part of the rail moving means for progressive bending of the rail laterally, as defined in claim 1.

- 4.9 In conclusion, the amendments to independent claims 1 and 28 meet the requirements of Article 123(2) and (3) EPC.
- 4.10 Dependent claim 5 differs from claim 5 as granted in that it has been amended to refer to "two spaced apart support members", instead of "a plurality of spaced apart support members". This amendment is supported by the information in the application documents as originally filed (see dependent claim 7).
- 4.11 The amendments to claims 1, 5 and 28 do not introduce non-compliance with Article 84 EPC. This has not been contested by the opponent.
5. Auxiliary request 2 - Novelty
- 5.1 The apparatus disclosed in D1 comprises front rollers 14 and tongs 19 which both constitute rail moving means for progressive bending of a rail laterally, as the apparatus moves along the railway (see point 1.13 above). They are, in use, operative outside the footprint of the apparatus on the ground (see figure above), contrary to the added feature of claim 1.
- 5.2 The apparatus defined in claim 1 thus differs from that disclosed in D1 by the feature that "the railway rail handling apparatus has no rail moving means which is, in use, operative outside the footprint of the apparatus on the ground". Hence, it is novel.

6. Auxiliary request 2 - Inventive step
- 6.1 Starting from D1, the problem objectively solved by this distinguishing feature can be seen as how to improve the apparatus' stability during operation.
- 6.2 The Board is not persuaded by the opponent's argument that the skilled person, in the expectation of solving this problem, could and indeed would modify the apparatus of D1 so as to arrive at the claimed invention.
- 6.3 The skilled person is not provided with a clear motivation to modify the apparatus of D1 in the claimed manner. Instead, using the common general knowledge in the art, he would rather consider improving the apparatus' stability by placing a counterweight at the rear end of the vehicle to balance the weight of the crane boom 2 and that part of the weight of the old and new rails which is taken up by the front arms 12 and the crane boom 2.
- 6.4 The opponent argues that the skilled person looking to improve stability would inevitably recognise the front rollers 15 and the front tongs 19 as sources of imbalances and bring them within the footprint of the apparatus. However, D1 teaches away from such a modification. Indeed, it is stated on column 2, lines 5 to 9 of D1 that "the invention realizes in the smallest possible space and with the most simple means a mode of operation which facilitates the continuous replacement [sic] of pairs of rails in a progressive and economical manner". This statement would hinder the skilled person from displacing the front rollers 14 and tongs 19 towards the rear rollers 15 and tongs 20, as this would most likely jeopardise the continuous crossing and

bending of the old and new rails underneath the vehicle as achieved in D1. Besides, no evidence has been provided to support the opponent's assertion that - using common general knowledge - the skilled person would inevitably displace the front rollers 14 and tongs 19 so that they are operative within the footprint of the apparatus.

6.5 The opponent further argues that the skilled person seeking an alternative solution to improve stability would readily widen the footprint of the apparatus to such extent that front rollers 14 and tongs 19 would be operative within the footprint, as required by the added feature of claim 1. The Board is not convinced. Whilst it is generally known in the field of crane vehicles that stability can be improved by extending the footprint of the vehicle, e.g. by means of extending outriggers, there is no evidence indicating that the claimed feature would be the inevitable result of a standard extension of the footprint of the crane vehicle of D1. Moreover, since it is essential in D1 to permit ready access for the workers to the front of the vehicle to lift the rail ends with the crane boom 2 and engage them with the rollers 14 and the tongs 19, it is unlikely that the skilled person would widen the footprint of the vehicle to such extent that it includes the front rollers 14 and tongs 19.

6.6 In conclusion, the Board is not convinced that the subject-matter of claim 1 lacks an inventive step when starting from D1.

6.7 In its written submissions, the opponent also argued that the claimed subject-matter lacked an inventive step when starting from D3 as closest prior art. In its communication pursuant to Article 15(1) RPBA the Board

addressed this objection and expressed its intention to limit the discussion only to the objection of lack of inventive step starting from D1, in particular because D1 appeared to be the most promising and relevant starting point, rather than D3 (see point 8 of the communication). In response, the opponent neither commented upon nor disputed this opinion and in particular did not refer to it in the oral proceedings, and the Board sees no reason to depart from its preliminary opinion. Hence, there is no need to address the objection based on D3 any further.

7. The above reasoning applies *mutatis mutandis* to the subject-matter of independent method claim 28.
8. For the reasons set out above, neither the grounds for opposition raised by the opponent nor the objection raised by the opponent under Article 123(2) EPC prejudice the maintenance of the patent as amended according to auxiliary request 2.
9. The description is in conformity with the amended claims (see amendments to paragraphs 6, 8 and 43 of the patent specification). This was not disputed by the opponent.
10. In light of this conclusion there is no need to consider auxiliary requests 3, 4a, 4b and 5 to 8 of the patent proprietor.

## Order

### For these reasons it is decided that:

1. The decision under appeal is set aside.
2. The case is remitted to the opposition division with the order to maintain the patent as amended in the following version:
  - claims 1 to 28 filed as auxiliary request 2 with letter dated 20 February 2018;
  - description, paragraphs [0001] to [0005], [0007], [0009] to [0042] and [0044] to [0056] of the patent specification, paragraphs [0006] and [0043] filed as auxiliary request 2 with letter dated 20 February 2018, and paragraph [0008] filed during the oral proceedings before the Board;
  - figures 1a, 1b, 2, 3a, 3b, 4, 5a and 5b of the patent specification.

The Registrar:

The Chairman:



C. Spira

G. Ashley

Decision electronically authenticated