

Internal distribution code:

- (A) [-] Publication in OJ
(B) [-] To Chairmen and Members
(C) [-] To Chairmen
(D) [X] No distribution

**Datasheet for the decision
of 18 June 2019**

Case Number: T 1837/16 - 3.3.07

Application Number: 03745781.9

Publication Number: 1496858

IPC: A61K9/00, A61K31/46, A61M15/00

Language of the proceedings: EN

Title of invention:
INHALATION KIT COMPRISUNG INHALABLE POWDER OF TIOTROPIUM

Patent Proprietor:
Boehringer Ingelheim Pharma GmbH & Co. KG

Opponents:
Teva UK Limited
Actavis Group PTC ehf
Vossius & Partner Patentanwälte Rechtsanwälte mbB

Headword:
INHALATION KIT COMPRISUNG INHALABLE POWDER OF TIOTROPIUM/
Boehringer Ingelheim Pharma GmbH & Co. KG

Relevant legal provisions:
EPC Art. 56

Keyword:

Inventive step - All requests (No)

Unclear parameter - Distinguishing feature for inventive step
(No)

Decisions cited:

Catchword:



Beschwerdekammern

Boards of Appeal

Chambres de recours

Boards of Appeal of the
European Patent Office
Richard-Reitzner-Allee 8
85540 Haar
GERMANY
Tel. +49 (0)89 2399-0
Fax +49 (0)89 2399-4465

Case Number: T 1837/16 - 3.3.07

D E C I S I O N
of Technical Board of Appeal 3.3.07
of 18 June 2019

Appellant: Boehringer Ingelheim Pharma GmbH & Co. KG
(Patent Proprietor) Binger Strasse 173
55216 Ingelheim am Rhein (DE)

Representative: Hoffmann Eitle
Patent- und Rechtsanwälte PartmbB
Arabellastraße 30
81925 München (DE)

Respondent: Teva UK Limited
(Opponent 1) Ridings Point
Whistler Drive
Castleford WF10 5HX (GB)

Representative: Elkington and Fife LLP
Prospect House
8 Pembroke Road
Sevenoaks, Kent TN13 1XR (GB)

Respondent: Actavis Group PTC ehf
(Opponent 2) Reykjavíkurvegi 76-78
220 Hafnarfjörður (IS)

Respondent: Vossius & Partner
(Opponent 3) Patentanwälte Rechtsanwälte mbB
Siebertstrasse 3
81675 München (DE)

Representative: Vossius & Partner
Patentanwälte Rechtsanwälte mbB
Siebertstrasse 3
81675 München (DE)

Decision under appeal: **Decision of the Opposition Division of the
European Patent Office posted on 7 June 2016
revoking European patent No. 1496858 pursuant to
Article 101(3) (b) EPC.**

Composition of the Board:

Chairwoman P. Schmitz
Members: D. Boulois
 S. Albrecht

Summary of Facts and Submissions

- I. European patent No. 1 496 858 was granted on the basis of a set of 8 claims.

Independent claim 5 as granted read as follows:

"5. Inhaler suitable for the administration of an inhalable powder containing tiotropium in an amount of 0.001 to 5 %, in admixture with a physiologically acceptable excipient with an average particle size of between 10 to 500 μm , said inhaler comprises a housing, containing two windows, a deck in which there are air inlet ports and which is provided with a screen secured via a screen housing, an inhalation chamber connected to the deck on which there is a push button provided with two sharpened pins and movable counter to a spring, a mouthpiece which is connected to the housing, the deck and a cover via a spindle to enable it to be flipped open or shut, and three holes with diameters below 1 mm in the central region around the capsule chamber and underneath the screen housing and screen, and further characterized in that said inhaler displays a flow resistance of about 0.01 - 0.1 $\sqrt{\text{kPa min/l}}$."

- II. The patent was opposed under Article 100 (a), (b), (c) EPC on the grounds that its subject-matter lacked novelty and inventive step, was not sufficiently disclosed, and extended beyond the content of the application as filed.

- III. The appeal lies from the decision of the opposition division to revoke the patent. The decision was based on the claims as granted as main request and 5 sets of claims filed as auxiliary requests 1 and 2 with letter of 26 February 2016, and filed during the oral

proceedings of 28 April 2016 as auxiliary requests 3,4 and 5.

IV. The documents cited during the opposition proceedings included the following:

D1: US 2004/0261792

D2: US 5 947 118

D4: US 6 116 237

D5: WO 00/21594

D6: WO 00/47200

D9: Terzano & Colombo, *Europ. Rev. Med. Pharm. Sciences*, 3, 1999, pp 247-254

D10: Bisgaard et al, *Drug Delivery to the Lung*

D11: DE 39 27 170

D12: WO 00/28979

D14: Chodosh et al, *J. of Aerosol Med.*, 14(3), 2001, pp 309-315

D16: DE 43 18 455

D18: US 355 029

D22: *Journal of Aerosol Medicine*, volume 6, number 2, 1993, p. 99-110

D23: *Thorax*, 1993, 48, 1186-1187

D29: Pictures of modified inhaler of type C

V. According to the decision under appeal, claim 8 of the main request lacked novelty over D6. Auxiliary requests 1 and 2 were not novel for the same reasons as the main request.

As regards auxiliary request 3, document D2 was chosen as closest prior art. The subject-matter of claim 5 which was identical to claim 5 as granted differed in the presence of three holes. The opposition division considered that the flow rate values were comparable for all the prior art inhalers. According to the opposition division, there was no proof that the flow

resistance was rendered more reliable or that the sidestream airflow would be compensated. A technical effect could not be derived and the problem was the provision of an alternative inhaler design. The skilled person would have expected at least a certain drop in airflow resistance when piercing the portion filter holder and deck. The solution was obvious and the request was not inventive.

Auxiliary requests 4 and 5 were not inventive for the same reasons.

VI. The patent proprietor (hereinafter the appellant) filed an appeal against said decision. With the statement setting out the grounds of appeal dated 17 October 2016, the appellant submitted auxiliary requests 1 to 5, experimental data and the following pieces of evidence:

D30: DE 1 491 715

D31: DE 3 345 722

The independent claims of the auxiliary requests, corresponding to claim 5 as granted (main request), read as follows, difference(s) compared with claim 5 as granted shown in bold:

Independent claim 5 of auxiliary request 1

Claim 5 was amended by a restriction as to the flow resistance, namely "and further characterized in that said inhaler displays a flow resistance of about **0.02 - 0.06** $\sqrt{\text{kPa min/l}}$ ".

Independent claim 4 of auxiliary request 2

Claim 4 was amended by the following feature, namely "and further characterized in that said inhaler displays a flow resistance of about **0.02 - 0.06** $\sqrt{\text{kPa}}$ min/l **and the deck has a reduced width in the range between deck and the housing near to the hinge, which forms the entrance slit for the air**".

Independent claim 5 of auxiliary request 3

Independent claim 5 of auxiliary request 3 was identical to independent claim 5 as granted.

Independent claim 5 of auxiliary request 4

Independent claim 5 of auxiliary request 4 was identical to independent claim 5 of auxiliary request 1.

Independent claim 4 of auxiliary request 5

Independent claim 4 of auxiliary request 5 was identical to independent claim 4 of auxiliary request 2.

- VII. With a letter dated 2 May 2017, opponent 01 (hereinafter respondent 01) submitted the following piece of evidence:
D32: USFDA submission on Spiriva Handihaler
- VIII. With a letter dated 11 May 2018, the appellant submitted the following pieces of evidence:
D33: Experimental Report
D34: Dutch periodical safety update report
- IX. A communication pursuant to Article 15(1) RPBA was sent to the parties. In this, it was stated in particular

that it seemed that none of the requests met the requirements of inventive step. It also stated that the parameter of "flow resistance" was unclear and could not be used to provide a further difference over the prior art.

- X. Oral proceedings took place on 18 June 2019 in the presence of the appellant and of respondent 01.
- XI. The arguments of the appellant may be summarised as follows:

Main request - Inventive step

The distinguishing features between the inhaler of claim 5 of the patent in suit and the inhaler shown in D2 were:

- i) the three holes
- ii) the screen
- iii) the screen housing, and
- iv) the specifically defined flow resistance.

The additional openings provided by the three holes, which could be at any position around the capsule chamber, such as on a plate at an unspecified place around the capsule chamber, compensated potential micrometer sized deviations of the flow cross-section of the inhaler and provided an inhaler with improved fluid mechanical properties. Reproducible delivery properties and thus the suitability for the administration of tiotropium were guaranteed by the three holes arranged in the central region of the inhaler around the capsule chamber and underneath the screen housing and the screen for compensating potential production tolerances. The experimental data provided on page 8 of the statement of grounds of

appeal showed that the claimed inhaler was characterized by an excellent recovery rate of almost 98 % of tiotropium bromide in comparison to the inhaler known from the closest prior art D2.

As regards the flow resistance, the skilled person would not have any difficulty in measuring it, in view for instance, of the method of measurement given in D22. The skilled person would in particular not use the method of D23 which was outdated.

The objective technical problem was defined as the provision of an improved inhaler for the administration of an inhalable powder containing tiotropium as active ingredient, which provided for an improved recovery rate of tiotropium and a reliable flow resistance independent of potential variations resulting from the manufacturing process of the inhaler.

The solution was not obvious in view of the cited prior art. D2 did not provide any hint or technical teaching based on which the skilled person would have been motivated to modify the inhaler disclosed therein in a way to arrive at the inhaler of the patent in suit. The solution was also not obvious in view of D4, D5, D9, D10, D11, D12 and D18. None of these documents filled the described gap in the technical teaching of D2. In particular the radial holes in document D4 could not be compared to the three holes as claimed, since these were arranged differently within the inhaler and hence clearly clearly had a different function than the three holes arranged underneath the screen/screen housing of the inhaler of the patent in suit.

Auxiliary request 1 - Inventive step

The appellant maintained mainly the same arguments as for the main request and did not submit anything special with regard to the amended features.

Auxiliary request 2 - Inventive step

The inhaler defined in amended claim 4 of auxiliary request 2 additionally differed from the inhaler disclosed in Figure 6 of D2 in that the deck had a reduced width in the range between deck and housing near to the hinge thereby forming entrance slits for the air/air inlet ports. The specific embodiment of the air inlet ports defined in claims 4 of auxiliary request 2 was to be taken into consideration when assessing the technical teaching of the prior art in view of the modifications being required for arriving at the claimed inhaler and the motivation of the skilled person to actually do so.

Auxiliary requests 3-5 - Inventive step

Auxiliary requests 3-5 contained the same claim relating to an inhaler as the main request, auxiliary request 1 and auxiliary request 2, respectively. The same arguments apply to these requests.

XII. The arguments of the respondents may be summarised as follows:

Respondent 03 objected the claimed parameter of flow resistance as not sufficiently disclosed, since in view of the different methods of measurement given in documents D22 and D23, the skilled person was not in a position to know with certainty for any given inhaler, whether the particular flow resistance fell inside or outside the scope of the claims. Respondent 01 also

objected said parameter as not sufficiently disclosed and mentioned in particular the fact that the size of the capsule with which the inhaler was to be used is not indicated in claim 5, while said capsule size was essential for measuring the flow resistance.

Main request - Inventive step

Respondent 03 considered in its written submissions that D2 and D14 were both possible closest prior arts.

Respondent 01 regarded D2 as the closest prior art. The inhaler of D2 did not disclose the following features of claim 5:

- (a) three holes with diameters below 1 mm in the central region around the capsule chamber and underneath the screen housing and screen; and
- (b) a flow resistance of 0.01 to 0.1 $\sqrt{\text{kPa min/l}}$.

The Opposition Division was right to conclude that the inhaler of D2 comprised a screen and a screen housing.

It was apparent that the three holes could not provide a meaningful technical effect. The wording of the claim was so unprecise that it was not clear where said holes were located. An effect would only be observed when the holes were arranged downstream the powder source, i.e. the capsule, and not when they were arranged upstream. Claim 5 of the patent allowed for the three holes to be arranged downstream or upstream of the powder source. Hence, the objective technical problem was to provide an alternative inhaler design.

The experimental evidence, and the effect of an improved recovery rate could not be taken into account. The reason for the reduced adherence of the powder in

the inhaler having the three holes (inhaler A), was that the holes created a so-called boundary layer of clean air between the powder-laden air and the inside walls of the mouthpiece. The boundary layer prevented the powder from directly contacting and adhering to the inside walls. The provision of a boundary layer of clean air between the powder-laden air and the walls of the mouthpiece of an inhaler could however only be created using radial holes which were positioned downstream of the powder source.

The claimed solution was arbitrary and obvious in view of D2 and also D4.

Auxiliary request 1 - Inventive step

Claim 1 of auxiliary request 1 restricted the ranges for flow resistance in claim 5. Obtaining such lower flow was obvious.

Auxiliary request 2 - Inventive step

The amended features were merely an arbitrary alternative to the openings illustrated in Figure 6 of D2.

Auxiliary requests 3 to 5

The same arguments applied to these requests.

XIII. Requests

The appellant requested that the decision under appeal be set aside and that the patent be maintained as granted, or alternatively that the patent be maintained according to one of the sets of claims filed as

auxiliary requests 1 to 5 with letter of 17 October 2016.

Respondents 01 and 03 requested that the appeal be dismissed.

Reasons for the Decision

1. Main request - Inventive step

1.1 The invention relates in claim 1 to an inhalation kit comprising a tiotropium containing powder and an inhalation device. Figure 1 shows a drawing corresponding to the specific embodiment of the inhaler as claimed in claim 5.

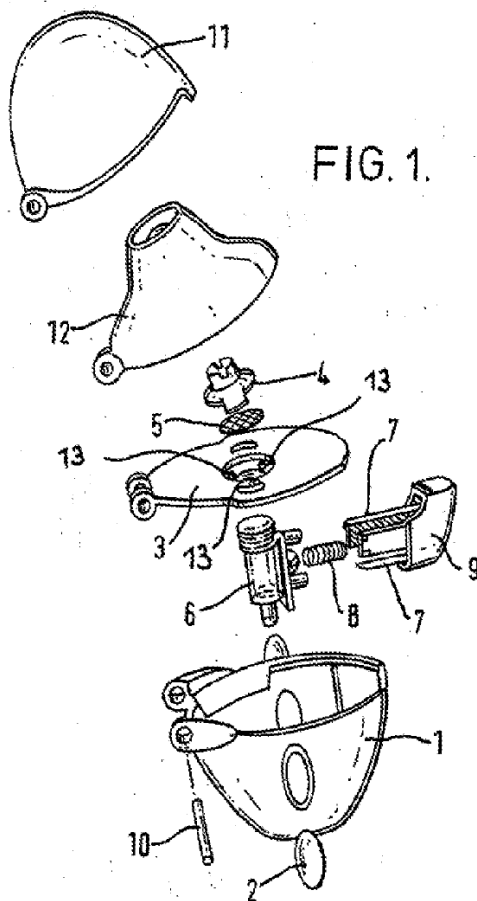

1.2 D2 was considered as the closest prior art and discloses an inhalation device illustrated by its Figure 6.

Figure 6 of D2:

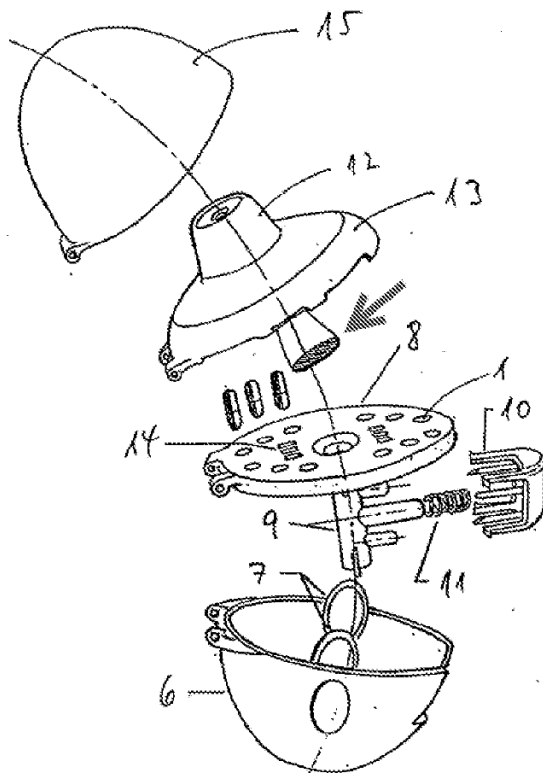

1.2.1 The appellant considers that the inhaler of claim 5 has the following distinguishing features over the inhaler disclosed in Figure 6 of D2:

- a) The three holes (reference 13 of Figure 1)
- b) The screen (reference 5 of Figure 1)
- c) The screen housing (reference 4 of Figure 1), and
- d) The specifically defined flow resistance.

1.2.2 The Board concurs as regards point a) but could however not follow the appellant's opinion as regards points b)-d).

The inhaler of Figure 6 of D2 comprises several openings through which air passes when the user inhales, located on the plate over the capsule chamber. It is however undeniable that the inhaler described in Figure 6 of D2 does not possess any holes located in

the central region around the capsule chamber and underneath the screen housing and screen. The presence of said three holes in the central region around the capsule chamber and underneath the screen housing and screen constitutes therefore indeed a distinguishing feature.

As regards the screen and the screen housing, Figure 6 of D2 shows a badly defined dashed surface indicated by the arrow which appears to be a screen sheltered in a screen housing. The presence of a screen is indeed usual and necessary since such screen must be present on an aerosol inhaler in order to avoid fragments of the capsule to be inhaled by the user. The presence of said screen is confirmed by the disclosure of other documents such as D18 which disclose aerosol inhalers of the same type as in D2 and having drawings with a better definition (see Figures 8 or 10 of D18). The presence of a screen and its housing does therefore not constitute a distinguishing feature.

As regards the specifically defined flow resistance of claim 5, namely comprised between $0.01 - 0.1 \sqrt{\text{kPa min/l}}$, appears to be the range characterizing most, if not all, of the known aerosol inhalers. In any case, the experimental data provided by the appellant with its statement of grounds of appeal dated 17 October 2016 show that the flow resistance of the inhaler of document D2 is about 0.0632, as shown by the following Tables, originating from the letter dated 17 October 2016, wherein the inhaler of document D2 is inhaler C (see the tables next page). Hence, the claimed flow resistance is also not a distinguishing feature.

Inhaler type	Modification	Remark
A	None	HandiHaler® of the commercial Spiriva® product of the Patentee; designed according to Fig. 1 and covered by claim 5 of the patent in suit
B	HandiHaler® with the three holes being closed	
C	HandiHaler® with air inlet ports and the three holes being closed and modified in accordance with Fig. 6 of D2 (see D29)	Closest prior art

Inhaler type	Flow resistance [$\sqrt{kPa \cdot min/l}$]
A	0.0516
B	0.0602
C	0.0632

1.2.3 Consequently, the only distinguishing feature between the subject-matter of claim 5 and D2 is the presence of three holes with a diameter below 1 mm in the central region around the capsule chamber and underneath the screen housing and screen.

1.3 According to the appellant, the problem is the provision of an improved inhaler for the administration of an inhalable powder containing tiotropium as active agent, which provides for an improved recovery rate of tiotropium and a reliable flow resistance independent of potential variations resulting from the manufacturing process of the inhaler.

1.4 The appellant has provided with its statement of grounds of appeal dated 17 October 2016 a comparison between said three inhaling devices A, B and C (See Tables above). A is the Handihaler according to the invention with three holes, B is a Handihaler with the three holes being closed, and C is a Handihaler with

air inlet ports and the three holes being closed and modified in accordance with Figure 6 of D2, as shown by the pictures of D29.

1.4.1 Said experiments show that the inhaling device A according to the invention, namely having three holes, provides an improved recovery rate of the powder, quantified at 97.8%, while an inhaler C according to D2 has a recovery rate of 91.9%.

Inhaler type	Delivered dose		Capsule residue		Sum delivered dose + capsule residue		Sum delivered dose + capsule residue rel. to labelled amount (18 µg)	
	average	standard deviation	average	standard deviation	average	standard deviation	average*	standard deviation
	[µg]	[%]	[µg]	[%]	[µg]	[%]	[%]	[%]
A	15.0	7.7	2.6	21.8	17.6	6.1	97.8	6.1
B	14.9	5.4	1.2	18.2	16.1	5.0	89.2	5.0
C	15.2	6.5	1.3	28.4	16.5	5.6	91.9	5.6

*The values indicated in this column result from averaging the single values obtained for the sum of the delivered dose and the capsule residue relative to the labelled amount. Due to rounding errors, the indicated average values do not exactly correspond to the values which can be calculated based in the results given for sum of the delivered dose and the capsule residue in the third column and the labelled amount of 18 µg.

According to the appellant, this means that less powder remains sticking on the inside walls of the inhaler A and a less turbulent airflow through the entire system consisting of inhaler and capsule, and a consequent constant delivery of powder dose of active agent.

Accordingly, said experiments show undeniably the existence of an effect linked with the presence of three holes.

1.4.2 However, the claimed inhaling device comprises "three holes with diameters below 1 mm in the central region around the capsule chamber and underneath the screen housing and screen" without any indication as to their position. This was confirmed by the appellant which

recognized that said holes could be located at any position around the capsule chamber of the inhaler, even on a plate at an unspecified position around the capsule chamber.

It is in particular not certain and/or specified in the claim whether the holes are located upstream or downstream the powder capsule. As explained convincingly by respondent 01, the reason for the reduced adherence of the powder in the inhaler having the three holes is that the holes create a boundary layer between the powder-laden air and the inside walls of the mouthpiece; said boundary layer prevents the powder from directly contacting and adhering to the inside walls. Said effect can however logically only be observed when the holes are arranged downstream the powder source, i.e the capsule, and not when they are arranged upstream. Claim 5 of the patent allows for the three holes to be arranged downstream or upstream of the powder source.

The effects demonstrated by the experiments correspond therefore to a specific inhalation device A with holes located downstream of the powder source, which is not specified by the subject-matter of claim 5; the inhaling device of claim 5 encompasses also devices having said three holes located upstream of the powder source, for which an effect as to an improvement in the powder recovery or in the air flow resistance is not shown and not credible.

Accordingly the effect shown by the experimental data of the appellant is linked with a specific type of inhaler and cannot be generalized to the inhaler as claimed in claim 5.

- 1.4.3 Accordingly, the problem must be reformulated as the provision of an alternative inhaling device.
- 1.5 It remains to be determined whether the claimed solution is obvious.
 - 1.5.1 Since the problem consists in the provision of an alternative inhaling device, it belongs to the normal activity of the skilled person to accomplish routine modifications, such as positioning holes, such as those present in Figure 6 of D2, at another position upstream of the powder source, i.e. the capsule. The positioning of such holes would be made as a matter of routine by a skilled person.

Moreover, the principle of holes for improving recovery rate of the powder is known from D4. D4 discloses the presence of radial holes to restrict air flow by design. Said holes provide a boundary layer for the powder-laden air in the front chamber, and said boundary layer helps to keep powdered drug from accumulating or collecting on the inside walls of the mouthpiece and is also believed to help to prevent the powder from settling out in the users mouth and throat (see D4, col. 6., 3rd par. and Fig. 2). The fact that said inhaler described in D4 is a dry powder inhaler and not an inhaler working with capsules of powder is irrelevant, since the powder circulation in the inhaler is comparable in both types of devices after inhalation by the user.

- 1.6 It follows that the inhaler claimed in claim 5 of the main request does not involve an inventive step, and the main request does not meet the requirements of Article 56 EPC.

2. Auxiliary request 1 - Inventive step

2.1 Claim 5 of auxiliary request 1 has been amended by the more specific flow resistance range of "**0.02 - 0.06** $\sqrt{\text{kPa min/l}}$ ".

2.2 As regards this parameter of "flow resistance", the description and the claims of the original application do not give any method of measurement or reference to a method of measurement of said "flow resistance". Moreover, the examples of the application as filed do not give any value of flow resistance of the disclosed inhaling device(s).

2.3 Some documents on file mention the parameter of "flow resistance" confirming that it was a known parameter at the priority date (cf. D4, D5, D9, D10).

Documents D22 and D23 were in particular filed by the appellant during the opposition proceedings to show that the parameter and at least two methods of measurement thereof were known at the priority date. According to these documents, the flow resistance appears to be the slope of the flow vs pressure drop curve.

The flow vs pressure drop curve as obtained by the method of measurement given in D22 is as follows:

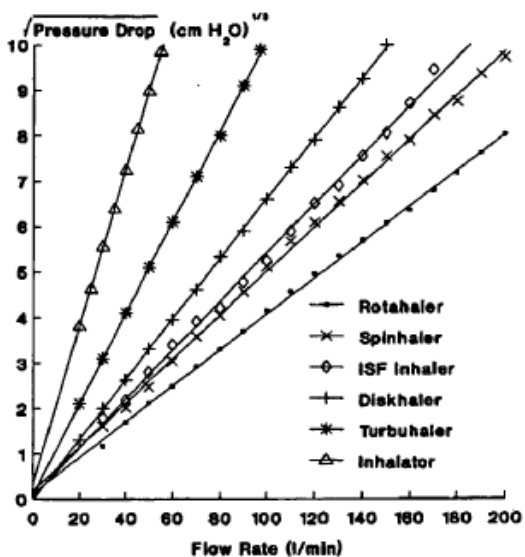

FIGURE 2. Pressure Drop Flow Rate Relationship for 6 Types of Commonly Used Powder Inhalers

The flow vs pressure drop curve as obtained by the method of measurement given in D23 is as follows:

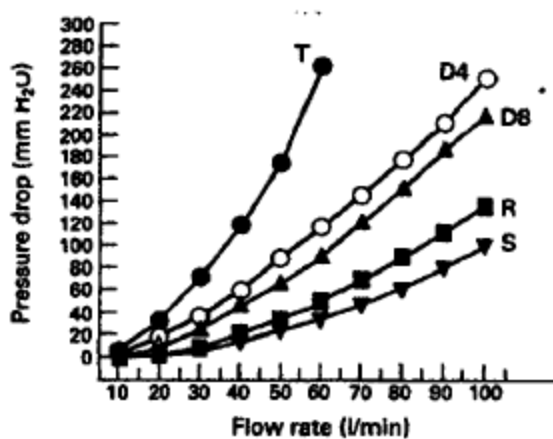

Figure 2 Mean pressure/flow relationship of five dry powder inhalers. T—Turbuhaler (●); D4—Diskhaler four place (○); D8—Diskhaler eight place (▲); R—Rotahaler (■); S—Spinhaler (▼).

It is immediately apparent from the disclosure of documents D22 and D23, in particular from the different curves disclosed therein, that the different methods of measurement given therein provide significantly

different results as regards the flow resistance values. This was illustrated by the calculations of respondent 03 in its reply to the statement of grounds of appeal and confirmed by the appellant which provided the following explicit comparisons of flow resistance values for some specific known inhalers:

Device	Flow resistance [cmH ₂ O ^{1/2} ,min/l]	
	D22 (Table 1)	D23 (calculated)
Turbohaler	0.100	0.086
Spinhaler	0.051	0.031
Diskhaler	0.067	0.050

2.4 The argument of the appellant that the method of D23 was older and outdated, and that the method of D22 had to be used, could in particular not be followed. Both documents have indeed been published the same year (1993), and even if D23 referred to an older method of measurement, it remains that at said time, both methods were still considered to be usable and reliable.

It is also clear that the parameter of "flow resistance" was not a standard or standardized parameter at the filing date of the contested patent, and still is not, and that one can even not exclude that further methods of measurement exist, in addition to the methods given in D22 and D23.

2.5 Moreover, even if, as argued by the appellant, the method disclosed in D22 would have the preference of the skilled person, said method still presents a certain imprecision. This is shown by the following

table provided by the appellant in its letter of 11 May 2018, which compares the values of "flow resistance" obtained for some inhalers in D33 with values obtained for the same inhalers in D22. For instance, the measured flow resistance of the Diskhaler has a variability of 0.03 $\sqrt{\text{kPa}\cdot\text{min}/\text{l}}$. Moreover, these measurements are not accompanied by any statistical parameter relating to the variability of the measured flow resistance.

Device	Flow resistance [$\text{cmH}_2\text{O}^{1/2}\cdot\text{min}/\text{l}$]	
	D33	D22 (Table 2)
Spinhaler	0.05	0.051
Rotahaler	0.04	0.040
Diskhaler	0.07	0.067

Such variability is all the more problematic as the value of flow resistance of the inhaler according to D2 and as measured is 0.0632 $\sqrt{\text{kPa}\cdot\text{min}/\text{l}}$ and thus is close to the upper limit of the claimed range of 0.02-0.06 $\sqrt{\text{kPa}\cdot\text{min}/\text{l}}$.

2.6 From all points above, it results that the claimed parameter has a certain variability and imprecision depending on the method of measurement used, or even when using a single method of measurement, and that said parameter is unable to provide a clear and unequivocal delimitation of the claim and/or comparison between two inhalers.

This variability and resulting unclarity has the consequence that the claimed parameter does not appear

to be able to delimit the scope of the claim clearly and unequivocally, in particular over the prior art D2. Accordingly, said parameter range cannot constitute a further distinguishing feature over the prior art.

- 2.7 In view of the above, the assessment on inventive step boils down to the same situation as for the main request, and the conclusion drawn previously for claim 5 of the main request applies mutatis mutandis to claim 5 of auxiliary request 1. Thus, the subject-matter of claim 5 of the auxiliary request 1 is obvious and auxiliary request 1 does not meet the requirements of Article 56 EPC.

3. Auxiliary request 2 - Inventive step

- 3.1 Claim 4 was amended by the following features, namely "and further characterized in that said inhaler displays a flow resistance of about **0.02 - 0.06** $\sqrt{\text{kPa}}$ min/l **and the deck has a reduced width in the range between deck and housing near to the hinge, which forms the entrance slit for the air**".

- 3.2 As discussed above for auxiliary request 1, the limitation of the range value of flow resistance is not seen as a further distinguishing feature. It has therefore no incidence on the assessment of inventive step.

The only further distinguishing feature, apart from the presence of the three holes with a diameter below 1 mm in the central region around the capsule chamber and underneath the screen housing and screen, is therefore the feature that **"the deck has a reduced width in the range between deck and housing near to the hinge, which forms the entrance slit for the air"**.

3.3 According to the appellant, the combination of the functional and structural features of claim 4 of auxiliary request 2 provides an inhaling device with the claimed range of flow resistance.

As discussed above for auxiliary request 1 (see point 2.6), the claimed parameter of flow resistance is in the present case unable to provide a clear and unequivocal delimitation of the claim or a comparison between two inhalers. The argument of the appellant as to an effect on the flow resistance linked with the claimed slits is therefore irrelevant anyway.

Moreover, any effect linked with a particular structure of the deck, i.e the presence of slits near the hinge, cannot be generalized to the inhaling device as claimed in claim 4. For instance, the slits used in the inhaler tested in the tests provided with the letter dated 17 October 2016 have a specific size, while claim 4 refers to slits with "a reduced width". The size of the slits is thus not expressed clearly and only in the form of a relative term in claim 4, while it is clear that the size of said slits has a paramount importance on any effect these could have.

In the absence of any shown effect, and the impossibility anyway to generalize it to the inhaler as claimed in claim 4, the problem is the provision of an alternative inhaling device.

3.4 The solution, namely the presence of the feature that **"the deck has a reduced width in the range between deck and housing near to the hinge, which forms the entrance slit for the air"** is merely an arbitrary alternative to the openings illustrated in Figure 6 of D2, which the

skilled person would move to any part of the deck, including near the hinge to obtain an equivalent effect.

3.5 It follows that the inhaler claimed in claim 4 of auxiliary request 2 does not involve an inventive step, and the request does not meet the requirements of Article 56 EPC.

4. Auxiliary requests 3-5 - Inventive step

Since independent claim 5 of auxiliary request 3 was identical to claim 5 as granted, claim 5 of auxiliary request 4 was identical to claim 5 of auxiliary request 1 and claim 4 of auxiliary request 5 was identical to claim 4 of auxiliary request 2, the conclusions for the previous requests apply respectively also to auxiliary requests 3-5.

Consequently, none of auxiliary requests 3-5 meet the requirements of inventive step (Article 56 EPC).

Order

For these reasons it is decided that:

The appeal is dismissed.

The Registrar:

The Chairwoman:



K. Götz-Wein

P. Schmitz

Decision electronically authenticated