

**Internal distribution code:**

- (A) [ - ] Publication in OJ
- (B) [ - ] To Chairmen and Members
- (C) [ - ] To Chairmen
- (D) [ X ] No distribution

**Datasheet for the decision  
of 19 January 2022**

**Case Number:** T 2286/17 - 3.2.02

**Application Number:** 11726439.0

**Publication Number:** 2588168

**IPC:** A61M5/32, A61M5/50, A61M5/28

**Language of the proceedings:** EN

**Title of invention:**  
SAFETY DEVICE FOR A PRE-FILLED SYRINGE AND INJECTION DEVICE

**Patent Proprietor:**  
Sanofi-Aventis Deutschland GmbH

**Opponent:**  
Bock Wolfgang

**Headword:**

**Relevant legal provisions:**  
EPC Art. 54, 56

**Keyword:**  
Novelty - (yes)  
Inventive step - (yes)

**Decisions cited:**

**Catchword:**



**Beschwerdekammern**

**Boards of Appeal**

**Chambres de recours**

Boards of Appeal of the  
European Patent Office  
Richard-Reitzner-Allee 8  
85540 Haar  
GERMANY  
Tel. +49 (0)89 2399-0  
Fax +49 (0)89 2399-4465

Case Number: T 2286/17 - 3.2.02

**D E C I S I O N**  
**of Technical Board of Appeal 3.2.02**  
**of 19 January 2022**

**Appellant:** Bock Wolfgang  
(Opponent) Stuntzstrasse 33  
81677 München (DE)

**Representative:** Samson & Partner Patentanwälte mbB  
Widenmayerstraße 6  
80538 München (DE)

**Respondent:** Sanofi-Aventis Deutschland GmbH  
(Patent Proprietor) Brünigstraße 50  
65929 Frankfurt am Main (DE)

**Representative:** Brown, Alexander Edward  
Venner Shipley LLP  
200 Aldersgate  
London EC1A 4HD (GB)

**Decision under appeal:** **Decision of the Opposition Division of the  
European Patent Office posted on 3 August 2017  
rejecting the opposition filed against European  
patent No. 2588168 pursuant to Article 101(2)  
EPC**

**Composition of the Board:**

**Chairman** M. Alvazzi Delfrate  
**Members:** D. Ceccarelli  
Y. Podbielski

## Summary of Facts and Submissions

- I. The opponent has appealed against the Opposition Division's decision, posted on 3 August 2017, to reject the opposition against European patent No. 2 588 168.

The patent was opposed on the grounds of lack of novelty and lack of inventive step.

- II. Oral proceedings took place on 19 January 2022 by videoconference.

The appellant (opponent) requested that the decision under appeal be set aside and that the patent be revoked.

The respondent (patent proprietor) requested that the patent be maintained on the basis of one of auxiliary requests 3 to 35 filed with letter dated 30 April 2018, and auxiliary request 36 filed with letter dated 6 April 2021.

- III. The following documents are relevant for this decision:

D1: US-A-2009/0024093

D2: US-B-6,884,237

D5a: WO-A-2011/076280

- IV. Claim 1 of auxiliary request 3 reads as follows (amendments to claim 1 of the patent as granted highlighted by the Board):

"A safety device (1) for a pre-filled syringe (2) which comprises a hypodermic needle (2.1) attached to a distal end of the pre-filled syringe (2), the safety

device comprising

- a hollow support body (1.2) for mounting the pre-filled syringe (2) therein,
- a hollow needle shield (1.1) that is slidable relative to the support body (1.2),
- and guiding means for guiding the movement of the needle shield (1.1) relative to the support body (1.2), wherein the guiding means comprise:
  - a flexible arm (1.1.4) with a guide pin (1.1.3) extending from the flexible arm (1.1.4) in a radial direction,
  - a guide track (1.2.5), wherein the guide pin (1.1.3) protrudes into the guide track (1.2.5)
  - a separating wall (1.2.6) that extends into the guide track (1.2.5) in a direction parallel to a central axis (A) of the safety device (1) and
  - wherein the guide track comprises an inclined section (1.2.5.1) oriented at an angle with respect to the central axis (A),

wherein, when the needle shield (1.1) is slid relative to the support body (1.2), the guide pin (1.1.3) moves along the guide track (1.2.5) and the movement of the guide pin (1.1.3) along the guide track (1.2.5) is guided by the interplay of the flexible arm (1.1.4) and the separating wall (1.2.6), ~~characterized in that~~ and, wherein, when the needle shield (1.1) is slid relative to the support body (1.2) in a proximal direction from an initial position (I), the guide pin (1.1.3) first moves along the inclined section (1.2.5.1) of the guide track (1.2.5) to deflect the flexible arm (1.1.4) in a lateral direction (L) perpendicular to the central axis (A) and subsequently the guide pin (1.1.3) abuts the separating wall (1.2.6),

and ~~that~~ the safety device (1) comprises means (1.2.1, 1.2.2) for preventing relative rotation between the

support body (1.2) and the needle shield (1.1)."

- V. The appellant's arguments, where relevant to the present decision, can be summarised as follows:

*Novelty in view of D5a*

The subject-matter of claim 1 of auxiliary request 3 lacked novelty over D5a. In particular, D5a disclosed a safety device with a needle shield such that when the needle shield was slid relative to a support body in a proximal direction from an initial position, a guide pin first moved along an inclined section of a guide track to deflect a flexible arm in a lateral direction perpendicular to the central axis of the safety device and subsequently the guide pin abutted a separating wall extending into the guide track.

Figures 2b to 4b disclosed that engagement pin 5a was displaced by flank 4d in a direction perpendicular to the central axis, as also explained on page 23, lines 4 to 8, and subsequently, when located at element 4g, abutted a separating wall.

*Novelty in view of D1*

The subject-matter of claim 1 of auxiliary request 3 lacked novelty over D1. In particular, D1 disclosed the feature of a safety device comprising a hollow support body for mounting a pre-filled syringe therein.

It was irrelevant whether Figure 1 of the patent showed a hollow support body which completely enclosed a syringe, since this embodiment was neither part of the claimed inventive concept nor was it reflected in the claim wording, which defined the scope of protection.

Claim 1 of auxiliary request 3 did not define a support body for substantially surrounding a syringe. It did not define how far the support body had to extend over the syringe in an axial direction. Moreover, the plunger of the syringe of the embodiments of the patent was not in the interior of the hollow support body.

The claimed feature was anticipated by any body adapted to surround a part of a syringe in a radial direction, no matter how small that part was. The safety device disclosed in D1 was intended to at least partially cover the needle of an injection device (paragraph [0008]) and comprised a support provided with fixing means intended to secure the safety device to an injection device (paragraph [0009]). The support (3, Figure 2) comprised a hollow body for somehow surrounding an injection device in the form of a pre-filled syringe, since the syringe comprised a standard distal tip that could be fitted to a proximal base of the support for connection to the needle of the syringe (paragraph [0061]). Support 3 had a sufficient axial depth (Figure 5) for mounting the syringe therein such that the syringe was somehow surrounded by the support in a radial direction.

*Inventive step starting from D1*

If it was considered that D1 did not disclose a hollow support body for mounting a pre-filled syringe therein, then the subject-matter of claim 1 of auxiliary request 3 still lacked inventive step when starting from D1.

The distinguishing feature could be considered to solve the problem of how to optimise the device of D1 to protect the main part of the syringe body, or how to

(better) mount a pre-filled syringe to the safety device of D1.

It would have been obvious, for the person skilled in the art, to provide a longer support body which only covered not only the tip, but the whole body of the syringe. Providing such a longer support body would not have required re-designing the device of D1. It would have been technically simple, also in view of the fact that the support body of D1 was made of a plastic material. A longer support body would have made the connection more stable.

Furthermore, D2 taught a hollow support body as a suitable structure to mount a pre-filled syringe to the safety device of D1. How to adapt any hollow structure to support a pre-filled syringe was part of the general knowledge of the person skilled in the art.

Moreover, even if according to D1 it was an aim of the safety device to be usable with a number of different injection devices, it had to be considered that D1 could not provide a one-size-fits-all solution. There existed a number of different syringes with different distal ends to which the safety device of D1 could not be fitted.

VI. The respondent's arguments, where relevant to the present decision, can be summarised as follows:

*Novelty in view of D5a*

D5a failed to disclose a guide track in which a pin first travelled along an inclined section to deflect a flexible arm, before subsequently abutting a separating wall.

*Novelty in view of D1*

D1 did not disclose several claimed features. In particular, D1 did not disclose a safety device with a support body for mounting and receiving a syringe therein, nor any support of a syringe. The feature "a hollow support body (1.2) for mounting the pre-filled syringe (2) therein" in claim 1 of auxiliary request 3 did not merely require a component that could be fitted to a syringe. D1 disclosed a "proximal base" (19) to which a standard distal tip (18) of a syringe (17) could be fitted (paragraph [0060]). The proximal base of D1 was neither suitable for supporting a syringe, nor suitable for mounting a syringe therein, contrary to the normal meaning of what was explicitly recited in the claim. On the contrary, it was the syringe which supported the safety device of D1 on its tip.

It was irrelevant that the embodiments of the patent did not comprise a hollow support body housing the entire syringe, including its piston and its needle. This was not required by the claim language.

*Inventive step starting from D1*

D1 was a fundamentally different type of device to that of the patent.

The technical effect of the hollow support body for mounting a pre-filled syringe therein was to receive and support a specific configuration of syringe mounted within the hollow support body. The technical problem was therefore simplification of use of a syringe.

The person skilled in the art would not have considered modifying the device of D1 to include a hollow support

body to receive a pre-filled syringe. If the device of D1 was modified to include a hollow support body to receive a pre-filled syringe therein, the resulting device would only be usable with one specific type of syringe with a certain configuration and dimensions. However, D1 explicitly stated that its objective was to provide a device " ... that can be used ... with any injection device such as, for example, syringes, catheters and any other equivalent device" (paragraph [0007]). The usability of the safety device of D1 with various shapes and sizes of injection device was also evident from the description which stated that, in use, the safety device was connected to a "standard distal tip" of a syringe body (paragraph [0061]), i.e. the safety device was configured for connection to any injection device comprising an industry-standard universal tip shape. Whether there existed other injection devices with different, non-standardised, distal ends, was not decisive. D1 did not teach universal applicability, but simply taught away from modifying the safety device in any way which would limit the range of different injection devices it could be used with.

Hence, it was irrelevant how easily the safety device of D1 could be modified. In view of the teaching of D1, the person skilled in the art would not have made any modification to include a hollow support body for mounting a pre-filled syringe therein.

## **Reasons for the Decision**

### 1. The invention

The invention as defined in claim 1 of auxiliary

request 3 (based on claims 1 and 13; page 7, lines 23 to 24, page 17, lines 9 to 17, and page 22, line 32 to page 23, line 9; and the figures of the application as filed), relates to a safety device for a pre-filled syringe.

Devices of the claimed kind are used to prevent needle stick injuries by shielding and making inaccessible the needle of a pre-filled syringe after use. An embodiment according to the claimed invention is depicted in Figures 1 and 2 of the patent, reproduced below.

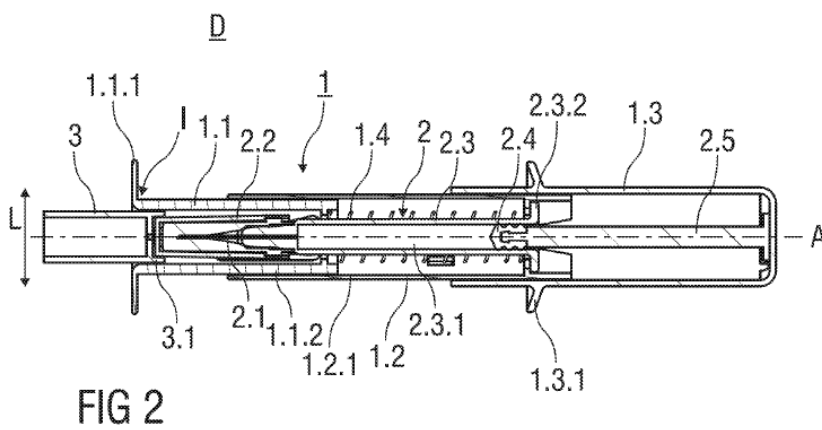
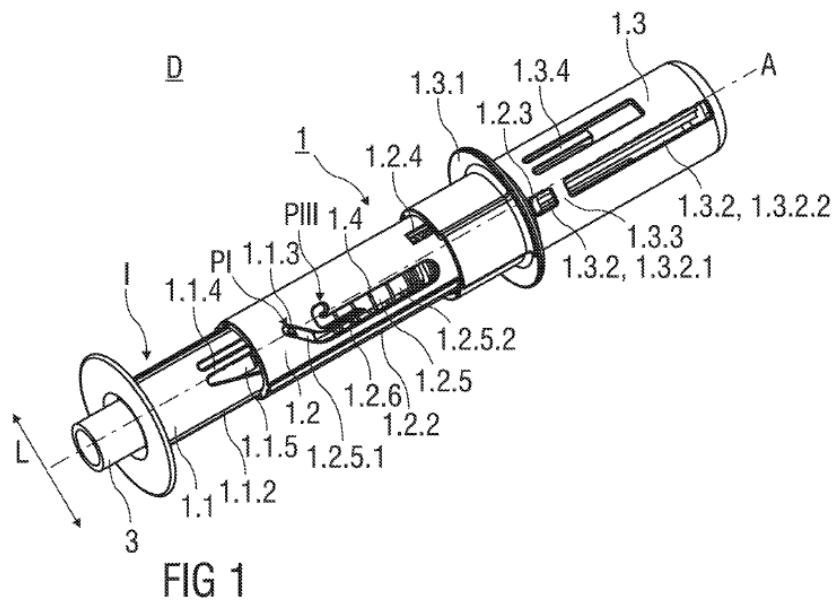

The safety device comprises a hollow support body (1.2) in which a pre-filled syringe (2) can be mounted, and a hollow needle shield (1.1) that is slidable relative to the support body.

The hollow support body and the needle shield, which are normally cylindrical, have a central longitudinal axis (A). The needle shield can be slid to an extended position in which it surrounds the needle of the pre-filled syringe.

Guiding means are provided for guiding the movement of the needle shield relative to the support body. The guiding means comprise a flexible arm (1.1.4) from which a guide pin (1.1.3) extends in a radial direction, a guide track (1.2.5) with an inclined section (1.2.5.1) oriented at an angle with respect to the central axis of the safety device, the guide pin protruding into the guide track, and a separating wall (1.2.6) that extends into the guide track in a direction parallel to the central axis.

When the needle shield is slid relative to the support body in a proximal direction from an initial position (I), the guide pin first moves along the inclined section of the guide track to deflect the flexible arm in a lateral direction (L) perpendicular to the central axis and subsequently the guide pin abuts the separating wall. This movement is also guided by the interplay of the flexible arm and the separating wall.

The safety device comprises means (1.2.1, 1.2.2) for preventing relative rotation between the support body and the needle shield.

As explained in detail in the description (paragraphs [0013] and [0014]), the separating wall is for separating two portions of the guide track. Accordingly, the guide pin may move along the first portion while the needle shield moves from an initial extended position to a retracted position in which an injection can be performed. Once the injection is performed, the guide pin may move along the second portion until the needle shield reaches a final extended position, in which the needle shield is locked.

2. Novelty in view of D5a

The appellant argued that the subject-matter of claim 1 of auxiliary request 3 lacked novelty over D5a.

D5a is prior art under Article 54(3) EPC. It discloses a safety device for a pre-filled syringe, as shown in its Figures 2b to 4b, reproduced below.

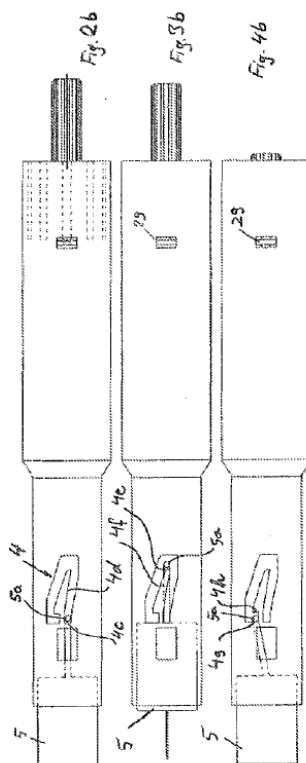

The safety device comprises a hollow support body, a hollow needle shield (5) and guiding means for guiding the movement of the needle shield relative to the support body, the guiding means comprising a flexible arm with a guide pin (5a), a guide track (4) and a separating wall (between the most distal parts of the guide track, adjacent to guide pin 5a in Figure 4b).

D5a does not disclose guiding means such that, when the needle shield is slid relative to the support body in a proximal direction from an initial position, the guide pin first moves along the inclined section of the guide track to deflect the flexible arm in a lateral direction perpendicular to the central axis and subsequently the guide pin abuts the separating wall.

The appellant argued that the guide pin abutted the separating wall after having been displaced by flank 4d in a direction perpendicular to the central axis. However, this is of little relevance since, according to claim 1 of auxiliary request 3, the guide pin has first to move along an inclined section of the guide track and only afterwards abut the separating wall. Instead, the guiding means of D5a are such that the guide pin contacts the separating wall already at the beginning of its movement through a non-inclined section of the guide track.

It follows that the subject-matter of claim 1 of auxiliary request 3 is novel (Article 54(1) and (3) EPC) over D5a.

3. Novelty in view of D1

The appellant argued that the subject-matter of claim 1 of auxiliary request 3 lacked novelty over D1.

D1 discloses (in particular in Figure 2 reproduced below) a protection device for protecting an injection needle.

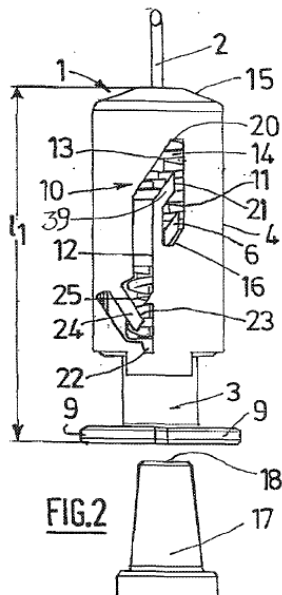

The protection device comprises a support (3) which can be fitted onto the distal tip of a syringe (17).

The Board shares the Opposition Division's view that D1 does not disclose a hollow support body for mounting a pre-filled syringe therein.

According to the normal technical meaning of the claim wording, the support body must be able to somehow surround or receive in its interior the syringe and support it. The description of the patent does not contradict this normal interpretation, as it discloses a syringe with its barrel substantially surrounded by the support body (Figure 2).

Although support 3 of D1 must have a certain axial depth for enabling its application onto a distal tip of a syringe, it is neither suitable for supporting a syringe, nor suitable for mounting a syringe therein

within the meaning of the claim wording.

The appellant's argument that any body adapted to surround even a small part of a syringe in a radial direction anticipated the claim wording is not convincing, as it assigns no limiting effect to the expressions "hollow support body" and "therein", stretching their normal technical meaning.

The fact that in the embodiments of the patent the plunger of the syringe is not in the interior of the hollow support body is irrelevant, as the claim wording does not mean that the support body must completely surround the syringe. This would make no technical sense. If also the needle of the syringe had to be surrounded by the support body no injection could be performed.

It follows that the subject-matter of claim 1 of auxiliary request 3 is novel (Article 54(1) and (2) EPC) over D1.

4. Inventive step starting from D1

As established above, D1 does not disclose a hollow support body for mounting a pre-filled syringe therein.

The appellant argued that this distinguishing feature could be considered to solve the problem of how to optimise the device of D1 to protect the main part of the syringe body, or how to (better) mount a pre-filled syringe to the safety device of D1.

The Board notes that even in view of these problems, the person skilled in the art would have received no hint from the cited prior art to provide the device of

D1 with a hollow support body as claimed.

As the respondent argued, if the device of D1 was modified to include a hollow support body to receive a pre-filled syringe therein, the resulting device would only be usable with one specific type of syringe with a certain configuration and dimensions.

The modification would go against the teaching of D1, which stresses the advantage that its safety device can be used "with any injection device, such as, for example, syringes, catheters and any other equivalent device" (paragraph [0007]).

In view of these circumstances it is irrelevant whether the modification as such would have been technically simple, shown as such in D2, or even part of the common general knowledge.

The appellant's argument that there still existed a number of different syringes with different distal ends to which the safety device of D1 could not be fitted is not convincing. Even if the safety device of D1 cannot have universal applicability, the possibility of using it with a large number of standardised injection devices is an advantage which the person skilled in the art would not have done away with, absent any express teaching to do so.

It follows that the subject-matter of claim 1 of auxiliary request 3 is inventive (Article 56 EPC) in view of the prior art relied on by the appellant.

5. It is common ground that the description of the patent specification is in conformity with the claims according to auxiliary request 3.

## Order

### For these reasons it is decided that:

1. The decision under appeal is set aside.
2. The case is remitted to the Opposition Division with the order to maintain the patent in amended form in the following version:
  - claims 1-17 of auxiliary request 3 filed with letter dated 30 April 2018
  - description and figures of the patent specification.

The Registrar:

The Chairman:



D. Hampe

M. Alvazzi Delfrate

Decision electronically authenticated