

**Internal distribution code:**

- (A) [ - ] Publication in OJ
- (B) [ - ] To Chairmen and Members
- (C) [ - ] To Chairmen
- (D) [ X ] No distribution

**Datasheet for the decision  
of 24 November 2025**

**Case Number:** T 2407/22 - 3.5.01

**Application Number:** 18212005.5

**Publication Number:** 3499698

**IPC:** H02M1/38, H02M7/48, H02M7/5395

**Language of the proceedings:** EN

**Title of invention:**  
ISOLATED INVERTERS

**Applicant:**  
Discovery Energy, LLC

**Headword:**  
Line-to-neutral three-phase inverter with isolated DC buses/  
DISCOVERY ENERGY

**Relevant legal provisions:**  
EPC Art. 56, 84, 111(1), 123(2)  
RPBA 2020 Art. 11, 13(2)

**Keyword:**  
Inventive step - isolating the DC inputs of three single-phase  
inverters used to form a line-to-neutral three-phase system  
(unassessed distinguishing feature)  
Remittal to the department of first instance (yes)



**Beschwerdekammern**  
**Boards of Appeal**  
**Chambres de recours**

Boards of Appeal of the  
European Patent Office  
Richard-Reitzner-Allee 8  
85540 Haar  
GERMANY  
Tel. +49 (0)89 2399-0

Case Number: T 2407/22 - 3.5.01

**D E C I S I O N**  
**of Technical Board of Appeal 3.5.01**  
**of 24 November 2025**

**Appellant:** Discovery Energy, LLC  
(Applicant) 220 Twin Oaks Drive  
Kohler, WI 53044 (US)

**Representative:** Hoefler & Partner Patentanwälte mbB  
Pilgersheimer Straße 20  
81543 München (DE)

**Decision under appeal:** **Decision of the Examining Division of the  
European Patent Office posted on 20 May 2022  
refusing European patent application No.  
18212005.5 pursuant to Article 97(2) EPC.**

**Composition of the Board:**

**Chairman** M. Höhn  
**Members:** W. Zubrzycki  
E. Mille

## Summary of Facts and Submissions

- I. This is an appeal against the decision of the examining division to refuse the European patent application No. 18212005.5 for lack of inventive step (Article 56 EPC).
- II. The contested decision held that claim 1 of the main request did not involve an inventive step over D7 (*"Centralized Control for Parallel Operation of Distributed Generation Inverters in Microgrids"*, IEEE TRANSACTIONS ON SMART GRID, USA, vol. 3, no. 4, published on 1 December 2012) and claim 1 of the first, second and third auxiliary request did not involve an inventive step over D9 (Vashishtha Sanjay: *"1-phase inverter connection with 3-phase system"*, published on 17 January 2013, retrieved from the Internet on 2 November 2022)
- III. In the statement setting out the grounds of appeal, the appellant requested that the decision be set aside and a patent be granted on the basis of the refused requests. The appellant also provided arguments in favour of the inventive step of these requests and annexed the background documents A1 (Wikipedia entry: *"Ground Electricity"*, undated) and A2 (*"Erdung - Blitzschutz - Potentialausgleich: Einbindung von Photovoltaik-Anlagen auf Gebäuden"*, dated October 2011) to support these arguments.
- Furthermore, in the notice of appeal, the appellant requested that *"as an auxiliary measure"*, a date for oral proceedings be set.
- IV. In the communication accompanying the summons to oral proceedings, the Board set out its preliminary opinion

that all requests contained added subject-matter and lacked clarity (Articles 84 and 123(2) EPC).

Furthermore, the Board informed the appellant that, if these objections were overcome for the third auxiliary request, it intended to remit the case to the examining division for further prosecution on the basis of this request.

V. By letter of 17 September 2025, the appellant filed a new main request based on the previous third auxiliary request. Furthermore, they withdrew the previous main, first and second auxiliary requests as well as the request for oral proceedings.

VI. The oral proceedings were cancelled.

VII. The sole independent claim of the main request reads:

*"An isolated bus inverter system (20), comprising:*

*three single-phase inverter circuits (20A-20C);*

*at least one energy source (21A-21C); and*

*a controller (24) being characterized in*

*that the three inverter circuits (20A-20C) comprise respective DC sides which are electrically isolated with no connections between their inputs, directly or indirectly, wherein an indirect connection is a connection of a negative DC rail in a first inverter circuit (20A) of the three inverter circuits (20A-20C) and a negative DC rail in a second inverter circuit (20B) of the three inverter circuits (20A-20C) to ground, include a switching*

*array and are configured to provide a three-phase alternating current (AC) signal to an output;*

*that the three electrically isolated DC sides of the three inverter circuits (20A-20C) include said at least one energy source (21A-21C) isolated from the other DC sides of the three inverter circuits (20A-20C); and that said controller (24) is configured to generate timing signals for the three inverter circuits (20A-20C) to generate the AC signals for the output (314) based on signals received from the at least one energy source (21A-21C). "*

VIII. The appellant's arguments, insofar as relevant to the decision, are discussed below.

### **Reasons for the Decision**

1. Admittance
  - 1.1 The Board admits the main request into the proceedings under Article 13(2) RPBA.
  - 1.2 This request was filed in reaction to objections under Articles 123(2) and 84 EPC raised for the first time in the Board's communication. This constitutes an exceptional circumstance within the meaning of Article 13(2) RPBA, justifying the admittance of the request.
2. The claimed invention
  - 2.1 The invention in claim 1 concerns an isolated bus inverter system which generates a three-phase alternating current (AC) from a direct current (DC)

input, see paragraphs [2] and [3] of the original application.

- 2.2 More specifically, the invention generates a three-phase AC by combining AC outputs of three single-phase inverters that are controlled by switching signals from a single controller (preamble and last feature of claim 1), see Figure 3 and [28], [32] and [45].
- 2.3 The claim defines that the system comprises "*at least one energy source (21A-21C)*" and that "*DC sides of the three inverter circuits (20A-20C) include said at least one energy source (21A-21C)*", see preamble and the second feature of the characterising part. The Board interprets these formulations, in the light of the application (paragraph [42] and Figure 4), in the manner suggested by the reference signs (21A-21C), namely that each of the three inverters includes its own separate energy source.
- 2.4 While not claimed but disclosed in the application, outputs of the three inverters are connected in a wye configuration, with one side of the loads tied together to form a common neutral point, see [32] and Figure 3. As outlined at paragraph [36] of the application, tying the inverters' neutrals together "*may result in an undesirable circulating current within the inverter, difficulty controlling output voltage, and potentially inverter damage.*"
- 2.5 The invention addresses these problems by electrically isolating the inverters' DC sides, with no connections between their inputs directly or indirectly (first feature of the characterising part), wherein an indirect connection is defined as "*a connection of a negative DC rail in a first inverter circuit (20A) of*

the three inverter circuits (20A-20C) and a negative DC rail in a second inverter circuit (20B) of the three inverter circuits (20A-20C) to ground". Furthermore, the second feature of the characterising part defines that "at least one energy source (21A-21C) [is] isolated from the other DC sides of the three inverter circuits (20A-20C)".

3. Articles 84 and 123(2) EPC

The Board is satisfied that objections under Articles 84 and 123(2) EPC raised earlier in the proceedings, were overcome by amendments.

4. Article 56 EPC

4.1 The contested decision found that claim 1 lacked an inventive step (Article 56 EPC) over document D9.

It is a brief document whose relevant disclosure is effectively limited to a figure on page 2, reproduced below.

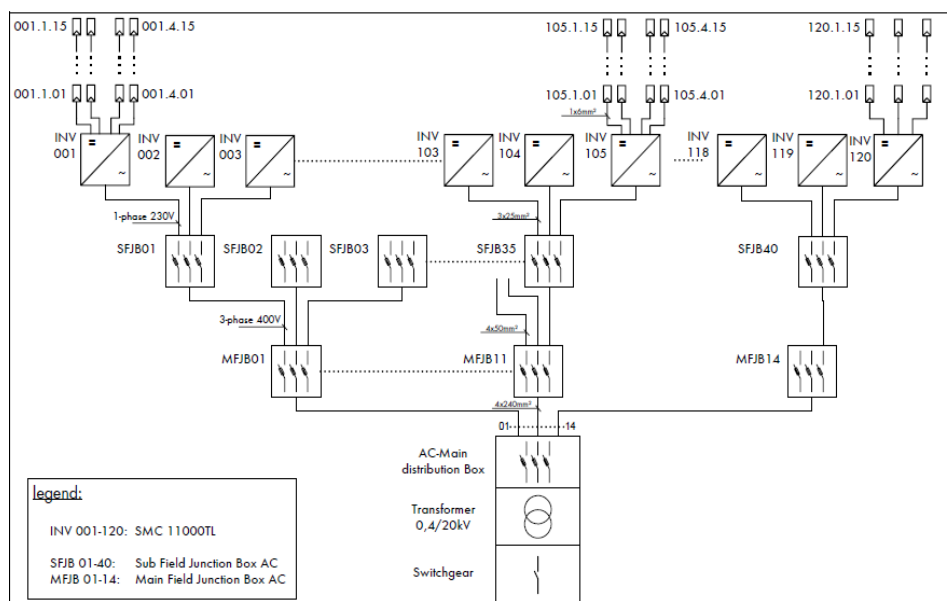

It is common ground that this figure illustrates the core idea of the present invention, namely, the grouping of three single-phase inverters (INV001...INV003 or INV103...INV105) to generate a three-phase AC output (at the bottom of the subfield junction box SFJB01), see decision, point 7.1.

The single-phase inverters are powered by photovoltaic (PV) strings, with the positive poles of four PV strings connected to each inverter. The three-phase AC they generate is delivered via junction boxes to a 0.4 kV/20 kV transformer connected to a power distribution grid.

- 4.2 The examining division (decision, point 7.1.1) considered that, apart from an aspect that is no longer present in the claim, the only novel feature of claim 1 was (labelling of the distinguishing features added by the Board):

U1) The use of a controller configured to generate timing signals for the plurality of inverter circuits (20A-20C) to generate the AC signals.

- 4.3 However, the Board agrees with the appellant and judges that claim 1 further differs from D9 in that:

U2) The respective DC sides of the three single-phase inverter circuits (20A-20C) are electrically isolated with no connections between their inputs, directly or indirectly, wherein an indirect connection is a connection of a negative DC rail in a first inverter circuit (20A) of the three inverter circuits (20A-20C) and a negative DC rail in a second inverter circuit (20B) of the three inverter circuits (20A-20C) to

ground.

U3) Said at least one energy source (21A-21C), included in the three isolated DC sides of the inverters, is isolated from the other DC sides of the three inverter circuits (20A-20C).

- 4.4 The examining division interpreted the fact that the figure reproduced above showed no connection between the solar strings and the DC sides of different inverters as implying electrical isolation between the inverters' DC sides. Therefore, in the examining division's view, features U2 and U3 were disclosed in D9, see decision, point 5.1, and minutes of the oral proceedings, point 2.2.
- 4.5 The appellant argued that this figure was a schematic, top-level depiction of the system, lacking any explicit disclosure of the actual wiring and grounding. Thus, the lack of connections or grounding in this conceptual figure was not a disclosure that they were not provided. Indeed, certain connection details were omitted despite clearly being present; for example, a three-phase 400 V connection was depicted as a single wire, even though it evidently represented several wires.
- 4.6 The Board agrees with the appellant and also considers that the figure in question is a conceptual representation of the system, which is not concerned with the actual wiring or grounding and leaves these details open.

The Board notes that, while the appellant expanded this argument on appeal, its core was already presented during the first-instance proceedings, see decision,

point 10.4.4.

- 4.7 This lack of specificity concerns, in particular, the wiring and grounding on the inverters' DC sides – the aspect on which features U2 and U3 focus.

Concerning the PV strings powering the inverters, the figure reproduced above shows their negative poles as floating. The appellant argued that, when read in the light of the skilled person's common general knowledge, as evidenced by A1 and A2, it would have been self-evident that the negative poles of these PV strings were grounded in order to dissipate high potentials caused by static electricity and to reduce potential-induced degradation.

The Board, however, judges that D9 simply leaves open whether any parts of the inverters' DC sides are grounded. It likewise leaves open whether the DC rails of the different inverters are interconnected or not.

- 4.8 Hence, the Board disagrees with the reasoning in the contested decision and judges that features U2 and U3, which define a specific wiring configuration at the inverters' DC sides, are novel over D9. Thus, these features must be examined for inventive step.

- 4.9 The examining division's assessment of inventive step was limited to feature U1. They essentially found in this respect that, starting from D9, using one controller for multiple inverters would have been an obvious manner of synchronising these inverters' AC outputs, see decision, point 5.4, fifth and sixth paragraphs. The appellant did not take issue with this finding and the Board judges that it is correct at least as regards controlling each group of three

single-phase inverters that together generate a three-phase AC.

4.10 Features U2 and U3, which the examining division considered to be disclosed in D9, were not assessed for inventive step.

4.11 Such an assessment would require a careful examination of possible technical motivations – such as those mentioned in the application – that could have prompted the skilled person to consider isolating the inverters' DC sides. This, in turn, requires consulting the prior art to determine whether it contains any indications or incentives pointing towards such an approach.

*Remittal*

5. In view of the above, the Board decides to remit the case to the examining division.

5.1 According to Article 111(1) EPC the Board may exercise any power within the competence of the examining division, which was responsible for the decision under appeal, or remit the case to the examining division for further prosecution. Article 11 RPBA lays down that the Board shall not remit a case to the department of the first instance, unless special reasons present themselves for doing so.

5.2 The Board considers it inappropriate to conduct the full assessment of inventive step for features U2 and U3 for the first time at the appeal stage. This is especially so as an additional search might prove necessary to identify prior art discussing electrical integration issues arising from combining three

single-phase inverters to generate a three-phase AC.

- 5.3 The Board judges that this is a special reason justifying the remittal to the examining division.
- 5.4 Accordingly, the Board remits the case to the examining division for assessing inventive step of the main request in view of the documents on file and, as the case may be, the results of an additional search.
6. Given that the appellant withdrew their auxiliary request for oral proceedings and the Board is positive on the appellant's main request, the decision is taken in writing.

## Order

### **For these reasons it is decided that:**

1. The decision under appeal is set aside.
2. The case is remitted to the examining division for further prosecution.

The Registrar:

The Chairman:



T. Buschek

M. Höhn

Decision electronically authenticated