

**Internal distribution code:**

- (A) [ - ] Publication in OJ
- (B) [ - ] To Chairmen and Members
- (C) [ - ] To Chairmen
- (D) [ X ] No distribution

**Datasheet for the decision  
of 26 January 2026**

**Case Number:** T 0261/23 - 3.3.07

**Application Number:** 16155384.7

**Publication Number:** 3058987

**IPC:** A61Q5/06, A61K8/73, A61K8/86,  
A61K8/891, A61K8/898

**Language of the proceedings:** EN

**Title of invention:**  
COMPOSITION FOR PROVIDING A FILM ON KERATIN FIBRES

**Patent Proprietor:**  
Wella Operations US, LLC

**Opponent:**  
Henkel AG & Co. KGaA

**Headword:**  
COMPOSITION FOR PROVIDING A FILM ON KERATIN FIBRES/Wella  
Operations US LLC

**Relevant legal provisions:**  
EPC Art. 54, 56

**Keyword:**  
Main request - Novelty and inventive step (Yes)



**Beschwerdekammern**

**Boards of Appeal**

**Chambres de recours**

Boards of Appeal of the  
European Patent Office  
Richard-Reitzner-Allee 8  
85540 Haar  
GERMANY  
Tel. +49 (0)89 2399-0

Case Number: T 0261/23 - 3.3.07

**D E C I S I O N**  
**of Technical Board of Appeal 3.3.07**  
**of 26 January 2026**

**Appellant:** Wella Operations US, LLC  
(Patent Proprietor) 4500 Park Granada, Suite 100  
Calabasas, CA 91302 (US)

**Representative:** Zimmermann & Partner  
Patentanwälte mbB  
Postfach 330 920  
80069 München (DE)

**Appellant:** Henkel AG & Co. KGaA  
(Opponent) Henkelstrasse 67  
40589 Düsseldorf (DE)

**Representative:** Henkel AG & Co. KGaA  
CLI / Patente  
40191 Düsseldorf (DE)

**Decision under appeal:** **Interlocutory decision of the Opposition  
Division of the European Patent Office posted on  
15 December 2022 concerning maintenance of the  
European Patent No. 3058987 in amended form.**

**Composition of the Board:**

**Chairman** A. Uselli  
**Members:** D. Boulois  
Y. Podbielski

## Summary of Facts and Submissions

- I. European patent No. 3 058 987 B1 was granted on the basis of a set of 14 claims.

Independent claim 1 as granted read as follows:

"1. A composition for providing a film on keratin fibres, the composition comprising:

(a) a film-forming aminosilicone polymer, wherein the aminosilicone polymer comprises amino sidechains, and wherein the aminosilicone polymer has a weight average molecular weight of from 10,000 Dalton to 60,000 Dalton;

(b) a silicone resin wherein the silicone resin is a MQ resin; (c) a thickening system comprising:

- a deposition enhancer, wherein the deposition enhancer is a hydrophilic and non-ionic polymer, and wherein the deposition enhancer has a weight average molecular weight of from 700,000 Dalton to 3,000,000 Dalton;

- a thickening polymer, wherein the thickening polymer has a weight average molecular weight of at least 10,000 Dalton, and wherein the thickening polymer is a cationic thickening polymer or is a non-ionic thickening polymer; and

(d) a solvent."

- II. The patent had been opposed under Article 100 (a) EPC on the grounds that its subject-matter lacked novelty and inventive step.
- III. The appeal lies from the decision of the opposition division that the patent in amended form met the

requirements of the EPC. The decision was based on the claims as granted as the main request, and on auxiliary requests 1-3 filed during the oral proceedings on 8 November 2022.

IV. The documents cited during the opposition proceedings included the following:

D1: WO 2011/059696 A2  
D2: Wacker Belsil ADM 1100, technical data sheet  
D3: Natrosol, Hydroxyethylcellulose, Physical and chemical Properties, Aqualon data sheet  
D4: WO 2009/102758 A1  
D5: Luviskol® K 90 Powder, technical data sheet  
D6: Luviset Clear, technical data sheet  
D7: WO 2009/101546 A1  
D8: WO 2013/085577 A2  
D9: FR 2 958 544 A1  
D10: WO 2006/042179 A1  
D11: SCCS Opinion on HC Red 10  
D12: Submissions in examination EP16155384.7 dated 03.05.2018, received 08.05.2018  
D13: Annex to submissions in examination EP16155384 dated 03.05.2018, received 08.05.2018

V. According to the decision under appeal, claim 1 as granted was novel over D1, D4 and D7.

With regard to inventive step, D1 was considered to be the closest prior art. Claim 1 of the main request differed from example 4 in D1 in that the composition comprised (a) a film-forming aminosilicone polymer. The problem was the provision of alternative or further hair care products. The claimed solution was obvious in view of D8.

Claim 1 of auxiliary request 1 did not fulfil the requirements of Article 123(2) EPC. The subject-matter of claim 1 of auxiliary request 2 was lacking an inventive step for the same reasons as given for the main request.

The claims of auxiliary request 3 fulfilled the requirements of Articles 123(2) and (3) EPC; their subject-matter was novel in view of D1, D4 and D7, and inventive when starting from D1 as closest prior art. The patent in amended form, on the basis of auxiliary request 3, thus complied with the requirements of the Convention.

VI. The opponent (hereinafter the appellant-opponent) filed an appeal against said decision. With its statement of grounds of appeal, the appellant-opponent submitted the following document:

D14: EP 1 773 288 B1

VII. The patent-proprietor (hereinafter the appellant-proprietor), also filed an appeal against the decision. With its statement of grounds of appeal dated 24 April 2023, the appellant-proprietor filed auxiliary requests 1-13.

VIII. A communication from the Board, dated 5 August 2025 was sent to the parties. In it, the Board expressed its preliminary opinion that *inter alia* the claims as granted (main request) were novel and appeared to be inventive. There was no substantive submission from either party in response to the communication.

IX. With a letter dated 24 November 2025, the appellant-opponent withdrew its request for oral proceedings. The

oral proceedings, appointed for 11 December 2025, were subsequently cancelled.

- X. The arguments of the appellant-opponent may be summarised as follows:

Main request - Novelty

D1, D4 and D7 were novelty-destroying documents.

The composition of Example 4 of D1 comprised all the features of claim 1 of the patent in suit. The amino silicone 1 and 2 corresponded to the claimed aminosilicones and hydroxyethylcellulose-1 (Natrosol 250 HHR, Hercules) and fulfilled both the structural requirements of the patent in suit for a deposition enhancer and a thickener polymer.

In the example section, D4 disclosed a "Rapid drying gel" (D4, p. 18, lines 21-25), containing all the compounds of claim 1 as granted. The same applied to the "Rapid drying gel" disclosed in D7.

Main request - Inventive step

The claimed subject-matter was not inventive over D1 combined with D8. Since the patent in suit did not describe an unexpected effect based on the distinguishing feature, the problem over D1 was the provision of an alternative (see point 2.3.4.3 of the decision). The solution to this problem was suggested by D8. This document aimed to improve the colour retention of hair dyed with pigments (D8, [0004]) and proposed the use of the aminosilicones SF 1708 and Wacker HC 303 for this purpose. In the light of the

combination of D1 and D8, the claimed subject matter of the main request was not inventive.

XI. The arguments of the appellant-proprietor may be summarised as follows:

Lack of substantiation of the objection based on lack of novelty in view of D4 and D7

The appellant-opponent had not responded to the reasons under item 2.2.2 of the decision, wherein the opposition division decided that granted claim 1 was novel over each of references D4 and D7. The appellant-opponent had not set out clearly and concisely the reasons why it was requested that the decision under appeal be reversed.

Main request - Novelty

D1, example 4 disclosed Natrosol 250 HHR, which was a preferred thickening polymer of the contested opposed patent. However, Natrosol 250 HHR could not not simultaneously be a "deposition enhancer" in the sense of the opposed patent which required two different chemical entities. A deposition enhancer was therefore not disclosed in D1. In addition, D1 failed to disclose an aminosilicone polymer as claimed.

D4 and D7 also failed to disclose a film-forming aminosilicone polymer as claimed. It was not directly and unambiguously derivable from D4 whether Amine Oil 2 had a weight average molecular weight ranging between 10,000 Dalton and 60,000 Dalton. Similar remarks applied to document D7. The composition of example 8 again included the same Amine Oil 2 as in D4.

Main Request - Inventive step

Document D1 concerned a conditioning composition in combination with direct dyes, while the opposed patent was not about conditioning. D1 was not about adhering pigments (or coloured material) and was rather about improving the storage stability. Furthermore, D1 was not about forming a film on hair.

When starting from D1, the problem was the provision of an improved composition for adhering coloured materials or pigments in a sufficiently durable manner while not providing a bad hair feel. A skilled person starting from document D1 and faced with the technical problem, would not have arrived at the subject matter of granted claim 1. Example 4 of D1 concerned a rinse-off conditioning composition, and therefore the skilled person would neither have found an incentive to provide a composition for forming a film, nor would they have found any hint leading to the compositions of claim 1.

XII. Requests

The appellant-opponent requested that the decision under appeal be set aside and the patent be revoked.

The appellant-proprietor requested that the decision under appeal be set aside and the patent be maintained as granted (main request), or that the patent be maintained on the basis of one of auxiliary requests 1-13 filed with letter of 24 April 2023.

The appellant-proprietor also requested that D14 not be admitted into the appeal proceedings, and that the objections of the appellant-opponent of lack of novelty

in view of D4 and D7 not be admitted into the proceedings.

## **Reasons for the Decision**

### 1. Admittance of D14 into the appeal proceedings

This document has been filed by the appellant-opponent with its statement of grounds of appeal. It was filed as part of the discussion on inventive step with regard to auxiliary request 3 to show that particle sizes between 5  $\mu\text{m}$  and 40  $\mu\text{m}$  were common in cosmetics. As this issue has no bearing on the discussion of inventive step with regard to the main request, which is the only request considered in this decision, the Board sees no reason to consider the admittance of this document into the proceedings.

### 2. Lack of substantiation of the objection based on lack of novelty in view of D4 and D7

2.1 The appellant-proprietor has requested that the objections of lack of novelty in view of D4 and D7 not be admitted into the appeal proceedings because the appellant has failed to substantiate why the reasoning of the opposition division in point 2.2.2 of the impugned decision should be reversed (Article 12(3) and (5) RPBA).

2.2 For the reasons provided in paragraph 3 below, the Board considers that the objections for lack of novelty in view of D4 and D7 are not convincing.

Accordingly, the Board does not see the necessity to take a decision on the admissibility of these objections.

3. Main request - Novelty

3.1 D1, D4 and D7 were quoted as novelty-destroying documents by the appellant-opponent.

3.2 D1 relates to hair conditioning agents containing at least one cationic surfactant system, a direct dye, and a non-ionic thickener. Example 4 of D1 discloses a composition suitable for forming films containing:

- (a) 0.5 wt.% aminosilicone-1 (see definition on page 19 of D1, lines 4-9 and), 3.5 wt.% aminosilicone-2 (Wacker Belsil ADM 1100),
- (b) 0.0035 wt.% MQ resin (SR 1000, polytrimethyl hydrosilylsilicate, GE Silicones (D1, p. 19, line 13)) (M3),
- (c) 0.0025 wt.% hydroxyethylcellulose-1 (Natrosol 250 HHR, Hercules) (cf. D1, p. 18, last line)
- (d) water (ad 100 wt.%).

Component (a) - The Board notes first that the product "Aminosilicone 1" has a structural formula depicted in footnote 4 below the table giving the compositions of the examples of D1 as shown below:

Aminosilicone: Terminal aminosilicone which is available from GE having a viscosity 10,000mPa•s, and having following formula (III):

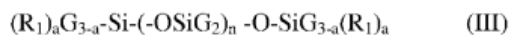

wherein G is methyl; a is an integer of 1; n is a number from about 400 to about 600; R<sub>1</sub> is a monovalent radical conforming to the general formula C<sub>q</sub>H<sub>2q</sub>L, wherein q is an integer of 3 and L is -NH<sub>2</sub>

Hence, "Aminosilicone 1" appears to be a **linear** polydimethylsiloxane with two terminal aminopropyl groups and not amino side chains; the molecular weight is furthermore not disclosed in D1. **The product aminosilicone-1 does therefore not correspond to the claimed aminosilicone polymer.**

The product "Aminosilicone-1" does also not correspond to the formula of paragraph [0038] of the contested patent as argued by the appellant-opponent. The figure of paragraph [0038] is given below:

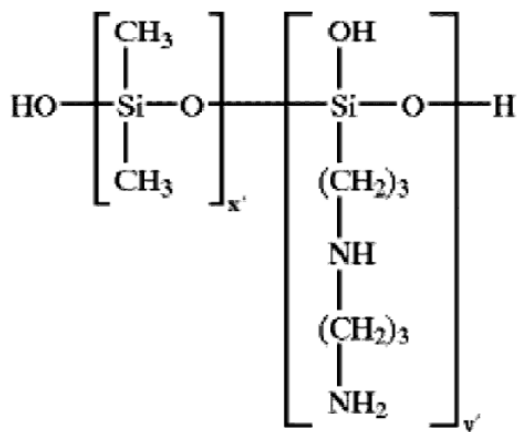

The structural formula of paragraph [0038] is indeed presented as defining a silicone "having pendent (graft) amino groups" wherein x' and y' are integers such that the average molecular weight is between 10,000 and 60,000. Under these conditions, it does not appear credible that y' may be equal to 1.

In addition, the structure of the lateral amino chain of the structure of paragraph [0038] is different from the amino end-chain of the product "Aminosilicone-1".

Component (b) - The product "Aminosilicone 2" is the commercial product Wacker-Belsil ADM1000 from Wacker

Silicone, as indicated in footnote 6 and in document D2. From D2, it is clear that "Aminosilicone 2" is an aminosilicone with amino side chains. **There is however no information in D1 or D2 about the average molecular weight of this polymer. It is therefore impossible to conclude that the product "Aminosilicone-2" corresponds to the claimed aminosilicone.**

Component (c)- The Board does also not agree with the appellant-opponent's argument that the hydroxyethylcellulose of example 4 is simultaneously a deposition enhancer and a thickening polymer. Claim 1 of the main requests makes a distinction between both categories of excipients and appears to exclude that the same compound can exert both functions.

In view of these points it appears clear that D1 cannot be novelty-destroying for the subject-matter of claim 1 of the main request.

3.3 D4 discloses on page 18 an example of "rapid drying gel" comprising and "Emulsion B", Luviset Clear, PVP 90, ethanol and water:

Rapid Drying Gel comprising 2.90 g Emulsion B, 1.00 g Luviset<sup>®</sup> Clear, 1.80 g Polyvinylpyrrolidone K 90; 1.00 g Direct dye; 1.50 g Surfactant 193; 1.00 g Synthalen<sup>®</sup> W 2000; 0.30 g AMP 95%; 0.30 g PEG-25 PABA (Uvinul<sup>®</sup> P 25); 0.15 g Panthenol; 0.30 g Perfume; 34.20 g Ethanol; 0.10 g Keratin hydrolysate; qsp 100.00 g with water.

Luviset is a non-ionic polymer of molecular weight of 270,000 Da acting as a thickener, while PVP 90 is a hydrophilic and non-ionic polymer with a molecular weight comprised between 1,100,000 and 2,000,000 Da acting as deposition inhibitor (see D5).

Said "Emulsion B" comprises an "Amine Oil 2" having functional amino radicals and Me<sub>3</sub>SiO terminal groups

and a MQ resin (see D4, page 18, lines 5-9 and page 17, 22-24, "Amine Oil 2"):

- Emulsion B: 16.g of a mixture of 11.1 g of Amine Oil 2 and 4.9 g of MQ resin are added to 6 g of water, 6 g of ethylene glycol monobutyl ether and 0.17 g of acetic acid at room temperature while stirring, and the remaining water to a total weight of 100 g is then also incorporated. A milky opaque emulsion is obtained. The emulsion is added at room temperature as last ingredient to the active solution/dispersion of the following examples.

The appellant-opponent considers that this product "Amine Oil 2" corresponds to the product Wacker HC 303 VP disclosed in the description of D4 on page 5, lines 8-11. The same passage of the description mentions also US2006/0041026 which is also mentioned in the contested patent in paragraphs [0042] and [0049] with regard to the suitable example of aminosilicone:

The polydimethylsiloxanes (P) and emulsions or dispersions thereof are described in US 2006/0041026 A1 which is hereby incorporated by reference. An oil-in-water emulsion of polydimethylsiloxanes (P) suitable for the invention is sold under the trademark Wacker® HC 303 VP by Wacker-Chemie AG (Germany).

The appellant-opponent argues furthermore that the product Wacker HC 303 has the same composition as the product Belsil ADM 8500 E (see D12).

However, as noted by the opposition division (see paragraph linking pages 8 and 9), D4 does not disclose in a direct and clear way which of the Amine Oils 1, 2 or 3 disclosed on the bottom of page 17 actually corresponds to the polydimethylsiloxanes described in US2006/0041026 or to the product "Wacker HC 303". In addition, there is no indication of the molecular weight of the aminosilicone used in D4 or in D12, and the opponent did not provide any detail as to the disclosure in document US2006/0041026. For this reason

alone, the composition of page 18 cannot be relevant for novelty.

The Board concurs therefore with the finding of the opposition division that D4 is not novelty-destroying for the subject-matter of claim 1 of the main request.

3.4 D7 discloses in example 41 a styling gel comprising an Emulsion C, PVP, Natrosol and water.

**Example 41: Styling gel**

PVP (LUVISKOL K 90 PULVER)	2.00 g
NATROSOL 250 HHR	0.50 g
Emulsion C	20.00 g
Eumulgin L	0.20 g
Perfume	0.15 g
UVINUL P 25	0.10 g
PHENOXYETHANOL	0.20 g
PHB-METHYLESTER	0.12 g
DISODIUM EDTA	0.10 g
Water	ad 100.00 g

"Emulsion C" contains "Amine Oil 3" and corresponds to the polydimethylsiloxanes described in US2006/0041026 or to "Wacker HC 303 VP" disclosed on page 8 of D7, which are also mentioned in paragraphs [0042] and [0049] of the patent.

It appears therefore impossible to identify clearly the aminosilicones disclosed in D7, and, for this reason, the claimed subject-matter is also novel over D7.

3.5 Accordingly, the main request is novel over the cited prior art, as concluded by the opposition division in its decision (Article 54 EPC).

4. Main request - Inventive step

4.1 The claimed invention relates to compositions for providing a film on keratin fibers, more particularly to compositions that provide more durable means to adhere pigments and coloured/shiny materials to keratin fibers (see par. [0001] or [0004] of the specification).

4.2 D1 was considered to represent the closest state of the art by the opposition division.

D1 is directed to hair conditioning compositions which at the same time may provide colouring benefits (see page 1). D1 observes that conditioners containing direct dyes need to be stored at higher pH than conditioners without dyes due to the better stability of the dye molecules at high pH. However, higher pH leads to other problems such as phase separation upon storage and undesirable hair colour (see D1, page 2). This problem is tackled by using a specific combination of surfactants in a specific pH, which gives a long-term colour stability (see pages 2 and 3 of D1). Silicone compounds are added to the compositions of D1 to provide smoothness and softness on dry hair (see page 13). D1 does not relate to a film-forming composition and does not aim to improve the adherence of pigment or colours to the hair.

The distinguishing features of the claimed subject-matter over example 4 of D1 are the specific aminosilicone and the thickening system.

4.3 The opposition division defined the problem over D1 as the provision of alternative or further hair care products. This definition of the problem was not

contested by the parties during the oral proceedings before the opposition division.

The appellant-proprietor defines the problem in its statement of grounds of appeal as the provision of an improved composition for adhering coloured materials or pigments in a sufficiently durable manner while not providing a bad hair feel.

4.4 The appellant-proprietor relies on the description of the patent to show an effect linked with the specific claimed aminosilicone and deposition enhancer.

4.4.1 According to the appellant-proprietor, the aminosilicone polymer enables forming a very thin, dry film, which tightly binds any coloured material and/or pigment onto the hair fibres in a durable fashion (par. [0028]). An aminosilicone polymer with a weight average molecular weight of below 10,000 Dalton results in a too runny support system which would not be suitable for forming a film. An aminosilicone polymer with a weight average molecular weight in excess of 60,000 Dalton results in a too hard and viscous support system which rather resembles a cured resin and is no longer suitable for forming a film.

The deposition enhancer is useful for aiding the deposition of the aminosilicone and silicone resin as well as any pigment and/or coloured material on to the hair fibre (par. [0051] and [0029]).

4.4.2 The Board notes that these properties are a simple repetition of the properties of the compounds given in the description of the patent.

Such general statements cannot constitute evidence of an improvement over a prior art document. However, having regard to the experimental data disclosed in the patent, the Board sees no reason to doubt that compositions of claim 1 are suitable for adhering coloured materials or pigments to keratine fibers. The Board considers therefore that the problem over D1 can be defined as the provision of an alternative hair care composition suitable for adhering coloured materials or pigments in a sufficiently durable manner to the hair.

- 4.5 With regard to obviousness, the appellant-opponent cites document D8.
- 4.5.1 D8 discloses a method of imparting a long-wearing colour to a keratinous substrate through the use of an aminosilicone similar to the aminosilicone of the contested patent, such as Wacker HC303 (see D8, claim 1, Figure 1, and the examples). Example IV of D8 also comprises polyquaterium 37 as thickener (see also D8, par. [0048]) and Figure 1 shows the improvement on wash resistance of the hair coloured with compositions comprising the product Wacker HC303.
- 4.5.2 In the Board's view, the paramount point to be responded to in the present case is whether the skilled person would have incorporated the specifically claimed aminosilicone and thickening system in the composition of example 4 of D1. Starting from D1, it must be established whether the skilled person would have modified the compositions disclosed therein and associate the teaching of this document to the teaching of D8 to arrive at a film-forming composition which helps to adhere pigments and coloured/shiny materials to keratin fibers.

Example 4 of D1 concerns a rinse-off conditioning composition. Accordingly, the skilled person would not derive from this example any relevant technical teaching regarding the provision of a film-forming composition capable of enhancing the adhesion of pigments and coloured or shiny materials to keratin fibers. Nor would they find in D1 any indication to modify the composition of example 4 by incorporating the products that distinguish claim 1, namely the specifically claimed aminosilicone and a deposition enhancer. The claimed subject-matter is therefore inventive over D1 for this reason alone.

Moreover, the Board agrees with the appellant-proprietor that the skilled person would have not combined the teaching of D1 with the teaching of D8. Example 4 of document D1 does not include pigments, and when starting from example 4 of D1 which includes direct dyes (and not pigments), the skilled person would not consult a reference which describes how to improve colour retention and colour fading for a pigment-based composition. Reference D8 does not suggest anywhere to combine the teaching with direct dyes or that colour retention and colour fading can be improved also when using direct dyes. The skilled person would therefore not consider the teaching of D8 when starting from D1.

4.6 Accordingly, the claimed subject-matter is inventive over D1 and the main request meets the requirements of Article 56 EPC.

**Order**

**For these reasons it is decided that:**

The decision under appeal is set aside.

The patent is maintained as granted.

The Registrar:

The Chairman:



B. Atienza Vivancos

A. Uselli

Decision electronically authenticated