

Internal distribution code:

- (A) [-] Publication in OJ
- (B) [-] To Chairmen and Members
- (C) [-] To Chairmen
- (D) [X] No distribution

**Datasheet for the decision
of 19 November 2025**

Case Number: T 1389/23 - 3.2.02

Application Number: 09788918.2

Publication Number: 2299938

IPC: A61F2/24

Language of the proceedings: EN

Title of invention:

COLLAPSIBLE AND RE-EXPANDABLE PROSTHETIC HEART VALVE CUFF
DESIGNS AND COMPLEMENTARY TECHNOLOGICAL APPLICATIONS

Patent Proprietor:

St. Jude Medical, LLC

Opponent:

Boston Scientific Corporation

Headword:

Relevant legal provisions:

EPC Art. 54, 56, 123(2)

RPBA 2020 Art. 12(4)

Keyword:

Novelty - main request (no) - auxiliary request 6 (yes)
Inventive step - auxiliary request 6 (yes)
Amendment to case - amendment within meaning of Art. 12(4)
 RPBA 2020 - auxiliary requests 1-2 admitted (no)
Amendments - added subject-matter - auxiliary requests 3-5
 (yes)

Decisions cited:

Catchword:



Beschwerdekammern

Boards of Appeal

Chambres de recours

Boards of Appeal of the
European Patent Office
Richard-Reitzner-Allee 8
85540 Haar
GERMANY
Tel. +49 (0)89 2399-0

Case Number: T 1389/23 - 3.2.02

D E C I S I O N
of Technical Board of Appeal 3.2.02
of 19 November 2025

Appellant: St. Jude Medical, LLC
(Patent Proprietor) 100 Abbott Park Road
Abbott Park, IL 60064 (US)

Representative: Gill Jennings & Every LLP
The Broadgate Tower
20 Primrose Street
London EC2A 2ES (GB)

Appellant: Boston Scientific Corporation
(Opponent) 300 Boston Scientific Way
Marlborough, MA 01752-1234 (US)

Representative: Peterreins Schley
Patent- und Rechtsanwälte PartG mbB
Hermann-Sack-Straße 3
80331 München (DE)

Decision under appeal: **Interlocutory decision of the Opposition
Division of the European Patent Office posted on
4 July 2023 concerning the maintenance of
European Patent No. 2299938 in amended form**

Composition of the Board:

Chairman M. Alvazzi Delfrate
Members: D. Ceccarelli
C. Schmidt

Summary of Facts and Submissions

I. The patent proprietor and the opponent appealed against the opposition division's decision that, account being taken of the amendments according to auxiliary request 4 made by the patent proprietor during the opposition proceedings, European patent No. 2 299 938 and the invention to which it relates met the requirements of the EPC.

II. Oral proceedings took place on 19 November 2025.

The proprietor requested that the decision under appeal be set aside and that the patent be maintained as granted (main request), or that the patent be maintained on the basis of one of the auxiliary requests 1 to 19, filed with the proprietor's letter dated 14 November 2023 setting out the grounds of appeal.

The opponent requested that the decision under appeal be set aside and that the patent be revoked.

III. The following documents are mentioned in this decision:

D2: WO 03/003949 A2

D3: US 2003/0040792 A1

D7: WO 2009/053497 A1

D9: WO 98/29057 A1

IV. **Claim 1 of the main request** reads as follows:

"A prosthetic heart valve for replacement of a native heart valve having a native valve annulus, comprising:

(a) a stent body (10) having a proximal end and a distal end and including a generally tubular annulus region (30) and a flare section (40) proximal to the annulus region (30), the stent body (10) having a proximal-to-distal axis (14), a radially collapsed condition and an unconstrained, fully radially expanded condition, the annulus region (30) and the flare section (40) increasing in diameter during transition from the radially collapsed condition to the radially expanded condition, the annulus region having a substantially constant diameter and the flare section (40) having a greater diameter than the annulus region (30) when the stent body (10) is in the radially expanded condition;

(b) one or more prosthetic valve elements (100) mounted to the stent body (10) and operative to allow flow in the antegrade direction through the annulus region (30) but to substantially block flow in the retrograde direction through the annulus region (30); and

(c) a cuff (85; 285) secured to the stent body (10), the cuff comprising

(i) a first cuff portion (80) covering an exterior surface of the annulus region (30) for disposition at the native valve annulus, the first cuff portion (80) having a first diameter when the stent body (10) is in the radially expanded condition, and
(ii) a second cuff portion (90) proximal to the first cuff portion (80), the second cuff portion (90) extending along an exterior surface of the flare section (40) of the stent body (10), the second cuff portion (90) having a second diameter when

the stent body (10) is in the radially expanded condition, the second diameter being greater than the first diameter, the second cuff portion (90) being adapted for engagement with native tissue proximal to the native valve annulus to form a seal with the native tissue which helps to block retrograde flow around the outside of the stent body, the first and second cuff portions being formed from a unitary sheet of material."

Claim 1 of auxiliary request 1 reads as claim 1 of the main request except that it contains the following additional wording at the end of the claim:

"; wherein the second cuff portion (90) also includes a layer of material (120) on the interior surface of the flare section (40) of the stent body (10) "

Claim 1 of auxiliary request 2 reads as claim 1 of auxiliary request 1 except that it contains the following additional wording at the end of the claim:

"; wherein the cuff is formed by folding the unitary sheet around the proximal edge of the stent body (10) "

Claim 1 of auxiliary request 3 reads as claim 1 of the main request except that it contains the following additional wording at the end of the claim:

", wherein the second cuff portion is thicker than the first cuff portion"

Claim 1 of auxiliary request 4 reads as claim 1 of auxiliary request 3 except that it contains the following additional wording at the end of the claim:

" , and wherein the second cuff portion (90) also includes a layer of material (120) on the interior surface of the flare section (40) of the stent body (10) "

Claim 1 of auxiliary request 5 reads as claim 1 of auxiliary request 4 except that it contains the following additional wording at the end of the claim:

" , and wherein the layer of material (120) is integral with the cuff material on the exterior of the stent and is formed by folding the unitary sheet around the proximal edge of the stent body (10) "

Claim 1 of auxiliary request 6 reads as claim 1 of the main request except that it contains the following additional wording at the end of the claim:

" , the second cuff portion (90) also includes a layer of material (120) on the interior surface of the flare section (40) of the stent body (10), thus the second cuff portion is thicker than the first cuff portion, and wherein the layer of material (120) is integral with the cuff material on the exterior of the stent and is formed by folding the unitary sheet around the proximal edge of the stent body (10) "

Claims 2 to 11 of auxiliary request 6 are dependent claims.

- V. The proprietor's arguments, where relevant to this decision, can be summarised as follows.

Main request - novelty over D2

D2 disclosed a prosthetic heart valve with a stent body and a sheath comprising different portions for replacement of a native heart valve having a native valve annulus. D2 did not disclose a second cuff portion being adapted for engagement with native tissue proximal to the native valve annulus to form a seal with the native tissue which helped to block retrograde flow around the outside of the stent body and first and second cuff portions being formed from a unitary sheet of material.

To the extent that the sheath of D2 comprised first and second cuff portions, these were not necessarily formed from a unitary sheet of material. Although the sheath was made from one type of material, it was not directly and unambiguously disclosed that it was formed from a single sheet. The sheath portions could be formed separately and then joined together.

Although D2 disclosed a portion of the sheath bearing against the wall of the ventricle of the heart, there was no disclosure of a seal with the native tissue which helped to block retrograde flow around the outside of the stent body. There was a distinction between sealing, which implied liquid tightness, and just engaging or anchoring. Moreover, according to claim 1 of the main request, it was the engagement between the second cuff portion and the native tissue, not the material of the seal, which was responsible for the formation of the seal.

Auxiliary requests 1 and 2 - admittance into the appeal proceedings

Auxiliary requests 1 and 2 should be admitted into the appeal proceedings. They had been filed in the first-instance proceedings, thus they were not entirely new. In the interest of procedural economy they had not been discussed during the first-instance proceedings. Claim 1 of auxiliary request 1 recited a feature of claim 8 as granted. This way of amending a claim by combining it with a dependent claim was a natural fall-back option. Claim 1 of auxiliary request 2 included a feature based on the description, page 14, lines 21 to 24, of the application as filed. If auxiliary requests 1 and 2 had been filed during the first-instance proceedings, the opposition division would have admitted them. Moreover, the amendments with respect to claim 1 of the patent as granted were not complex, established novelty and inventive step, and contributed to procedural economy by solving the novelty issue with respect to D2. Hence, auxiliary requests 1 and 2 should be admitted under Article 12(4) RPBA.

Auxiliary requests 3 to 5 - added subject-matter

Claim 1 of auxiliary request 3 found a basis in paragraph [0057] of the application as filed. The word "thus" in that paragraph [0057] indicated that the second cuff portion was thicker than the first cuff portion as a result of a layer of material on the interior. However, there was no indication that this was the only way to form a thicker second cuff portion. From the disclosure of the application as a whole, it would have been clear to the person skilled in the art that other configurations were possible. For example,

paragraph [0012] disclosed different regions of the cuff having different thicknesses without reference to a layer on the inside of the stent body. Paragraph [0058] indicated that the cuff portions could be made in a variety of ways. Paragraph [0060] mentioned the thick second portion without reference to a layer on the inside of the stent body. Moreover, a layer on the interior of the stent body was not inextricably linked to the feature of the second cuff portion being thicker than the first cuff portion.

In claim 1 of auxiliary requests 4 and 5, it had been specified that the second cuff portion also included a layer of material on the interior surface of the flare section of the stent body. A basis for these claims was paragraph [0057] of the application as filed. By specifying that the layer of material was present on the interior surface of the flare section of the stent body, all the necessary structural features disclosed in paragraph [0057] had been introduced. Moreover, it had been made clear that the second cuff portion being thicker was a consequence of the layer of material on the interior of the stent. Paragraphs [0058] and [0064] were unambiguous regarding the possibility of there being a further layer of material on the inside of the stent body. This meant that the person skilled in the art had been taught that the second cuff portion could be thicker not only in embodiments in which a layer of material was present on the inside of the stent body.

Auxiliary request 6 - novelty over D3 or D9

The subject-matter of claim 1 of auxiliary request 6 was novel over D3. D3 disclosed a prosthetic heart valve with a stent body, in the form of a support 420, Figure 13, and a cuff, in the form of an outer

sheath 482, Figures 14 and 15. D3 did not disclose a flare section of the stent body within the meaning of the claim. Moreover, D3 did not disclose that the cuff was adapted for engagement with native tissue proximal to the native valve annulus to form a seal with the native tissue which helped to block retrograde flow around the outside of the stent body. According to paragraph [0087] of D3 the cuff merely had the function of mitigating contact between the blood and the stent body. Also, the triangular elements 442 of the stent body in Figures 14 and 15 allowed retrograde flow, as blood could flow through the spaces between the triangles.

The subject-matter of claim 1 of auxiliary request 6 was novel over D9, too. If D9 was considered to disclose a prosthetic heart valve with a stent body having an annulus region and a flare section according to the claim, then there was no disclosure of a second cuff portion extending along an exterior surface of the flare section, being adapted for engagement with native tissue proximal to the native valve annulus and being thicker than a first cuff portion covering an exterior surface of the annulus region. Page 15, lines 3 to 9 of D9 did not disclose that opening-outs of the stent body engaged with the native tissue to reinforce embedding of the valve. It was the concave shape profile of the valve which reinforced the embedding, according to the above passage. Figure 6d disclosed that a sheath of material forming the cuff portions was folded over in the annulus region as well as in the flare section. Hence, the resulting thickness of the first and the second cuff portions was the same.

Auxiliary request 6 - inventive step starting from D7 or D9

D7 did not disclose an annulus region of a stent body with a substantially constant diameter. The claimed region implied a certain longitudinal extension. D7 did not disclose a second cuff portion including a layer of material on an interior surface of the stent body either. The person skilled in the art would have had no motivation to implement these features in the prosthetic heart valve disclosed in D7. The opponent had not provided any arguments in this respect.

D9 did not disclose a second cuff portion extending along an exterior surface of the flare section, being adapted for engagement with native tissue proximal to the native valve annulus and being thicker than a first cuff portion covering an exterior surface of the annulus region. The person skilled in the art would have had no motivation to implement these features in the prosthetic heart valve disclosed in D9. The opponent had not provided any arguments in this respect.

VI. The opponent's arguments, where relevant to this decision, can be summarised as follows.

Main request - novelty over D2

D2 disclosed a second cuff portion being adapted for engagement with native tissue proximal to the native valve annulus to form a seal with the native tissue which helped to block retrograde flow around the outside of the stent body. D2 disclosed engagement of the second cuff portion with the native tissue proximal to the native valve annulus (page 8, lines 23 to 26).

Such engagement anticipated the general definition of the seal in claim 1 of the main request, which did not prescribe any specific amount of sealing.

Moreover, D2 disclosed first and second cuff portions being formed from a unitary sheet of material. It disclosed a sheath made of a material (page 10, lines 8 to 10) and nowhere discloses separate pieces of material joined together.

Auxiliary requests 1 and 2 - admittance into the appeal proceedings

Auxiliary requests 1 and 2 should not be admitted into the appeal proceedings. After the discussion of novelty in relation to the main request in the oral proceedings before the opposition division, the proprietor decided to rank these requests lower than the request eventually found allowable by the division. Hence, it deliberately avoided a decision on current auxiliary requests 1 and 2. Moreover, these requests were procedurally complex to treat. For example, the feature of the thickness of the second cuff portion, which had been central to the discussion before the opposition division, was not present in their respective first claims.

Auxiliary requests 3 to 5 - added subject-matter

The application as filed disclosed the second cuff portion being thicker than the first cuff portion only as a consequence of an additional layer of material on the interior of the stent body (paragraph [0057]). This was not specified in the first claims of auxiliary requests 3 to 5. Hence, their subject-matter extended beyond the content of the application as filed.

Paragraph [0058] was directed to additional layers but neither compared cuff thicknesses on different stent portions nor was it indeed compatible with the disclosure of paragraph [0057], which required a unitary fold-over cuff. Paragraph [0060] only disclosed implantation of the previously described valve. Paragraph [0012] had nothing to do with the claimed embodiment but pertained to a cuff with bulge regions arranged around the circumference of the stent body as depicted in Figures 17 to 20 of the application as filed. Paragraph [0064] also related to different, non-claimed embodiments.

Auxiliary request 6 - novelty over D3 or D9

The subject-matter of claim 1 of auxiliary request 6 was not novel over D3. D3 disclosed a prosthetic heart valve with a stent body, in the form of a support 420, Figure 13, and a cuff, in the form of an outer sheath 482, Figures 14 and 15. D3 also disclosed a flare section of the stent body in the form of triangular projections 442, in Figures 13 to 15. Engagement of the outer sheath on these projections with native tissue provided a seal within the meaning of the claim, which was very general in this respect. Some portion of the outer cuff on the projections engaged the tissue and thus improved the seal.

The subject-matter of claim 1 of auxiliary request 6 was not novel over D9 either. D9 disclosed a prosthetic heart valve, the base of which was to be positioned at the level of the aortic annulus (page 22, lines 4 to 8). Figures 3a and 3b disclosed flare sections in the form of opening-outs at the ends of a stent body. The flare section at the inflow end was adapted for engagement with native tissue proximal to the native

valve annulus. A rolled-over cover (19'', Figure 6d) extended on the outside from the interior at the inflow end beyond the base of the valvular structure. Hence, the lower portion of the cover in Figure 6d was necessarily adapted for engagement with native tissue proximal to the native valve annulus and was thicker than a first cuff portion covering an exterior surface of the annulus region. Moreover, Figures 13j to 13l and page 15, lines 3 to 9 of D9 disclosed that the opening-outs of the stent body engaged with the native tissue to reinforce embedding of the valve.

Auxiliary request 6 - inventive step starting from D7 or D9

D7 disclosed a prosthetic heart valve with a stent body having a flared section and an annular region as defined in claim 1 of auxiliary request 6. The claim did not define any longitudinal extension of the generally tubular annulus region. The patent comprised embodiments with annular regions without any substantial longitudinal extension of constant diameter, such as the hourglass-shaped valve of Figures 2 and 3, and the valve with tapering portion 30 of Figure 5. Also in view of this disclosure of the patent, the waist between stent regions 102 and 104 in Figure 1A of D7 could be considered a tubular annulus region. Alternatively, the straight portions of the commissure regions shown in Figure 6 could also be considered to be the generally tubular annulus region within the meaning of the claim. Although D7 did not disclose a second cuff portion including a layer of material on an interior surface of the stent body, it would have been obvious to the person skilled in the art to fold over the cuff in order to provide a double layer of fabric. Hence, the subject-matter of claim 1

of auxiliary request 6 was not inventive when starting from D7.

If D9 was not considered to disclose a second cuff portion extending along an exterior surface of the flare section and being adapted to form a seal with the native tissue which helped to block retrograde flow because the rolled-over cuff resulted in triangular spaces around the outside of the stent body, then providing a folded-over cuff without such triangular spaces would have been obvious to the person skilled in the art. Hence, the subject-matter of claim 1 of auxiliary request 6 was not inventive when starting from D9.

Reasons for the Decision

1. Subject-matter of the patent

The patent is concerned with a prosthetic heart valve for replacement of a native heart valve having a native valve annulus.

Prosthetic heart valves are used for treating cardiac valvular disorders and are intended to replace defective native valves.

Figure 5 of the patent illustrates a schematic sectional view of an embodiment of a prosthetic heart valve according to claim 1 of the main request. This figure, completed by its mirror image to illustrate the generally tubular geometry of the valve, is reproduced below.

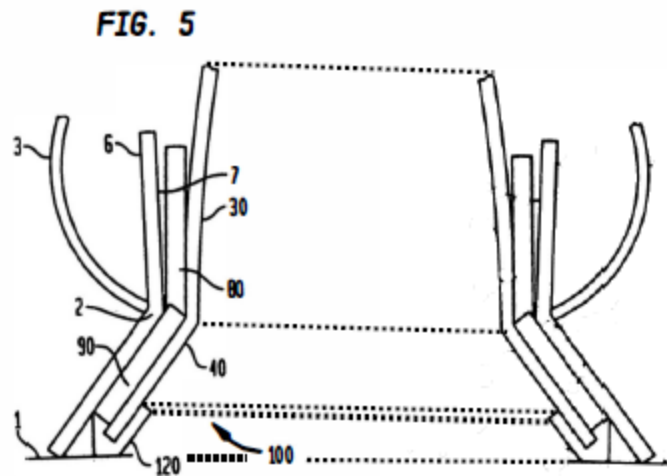

The claimed prosthetic heart valve comprises a stent body with a generally tubular annulus region (30) and a flare section (40) proximal to the annulus region, one or more prosthetic valve elements (100) mounted to the stent body and a cuff with a first cuff portion (80) and a second cuff portion (90) secured to the stent body.

The stent body has a proximal-to-distal axis with a proximal end and a distal end, a radially collapsed condition and an unconstrained, fully radially expanded condition. The generally tubular annulus region has a substantially constant diameter and the flare section has a greater diameter than the annulus region when the stent body is in the radially expanded condition. The annulus region and the flare section increase in diameter during transition from the radially collapsed condition to the radially expanded condition.

The prosthetic heart valve is in the radially collapsed condition for its introduction through vasculature to reach the heart. Once the deployment site at the native heart valve is reached, the prosthetic heart valve is radially expanded to be fixed in place.

The prosthetic valve elements are operative to allow flow in the antegrade direction through the annulus region but to substantially block flow in the retrograde direction through the annulus region.

The first cuff portion covers an exterior surface of the annulus region for disposition at the native valve annulus (2). The second cuff portion is proximal to the first cuff portion and extends along an exterior surface of the flare section of the stent body. With the stent body in the radially expanded condition, the second cuff portion has a diameter greater than the diameter of the first cuff portion. The second cuff portion is adapted for engagement with native tissue proximal to the native valve annulus to form a seal with the native tissue which helps to block retrograde flow around the outside of the stent body. The first and second cuff portions are formed from a unitary sheet of material.

The claimed features should provide a prosthetic heart valve with improved sealing and adequate anchoring capabilities, without excessive radial force that could harm nearby anatomy and physiology (column 2, lines 28 to 31 of the patent).

2. Main request - novelty over D2

The opposition division concluded that the subject-matter of claim 1 of the main request lacked novelty over D2.

2.1 It is common ground that D2 discloses a prosthetic heart valve for replacement of a native heart valve having a native valve annulus. Figures 1, 2 and 9 of

D2, reproduced below, provide schematic illustrations of a stent body, of a cuff and of the valve in the implanted state, respectively.

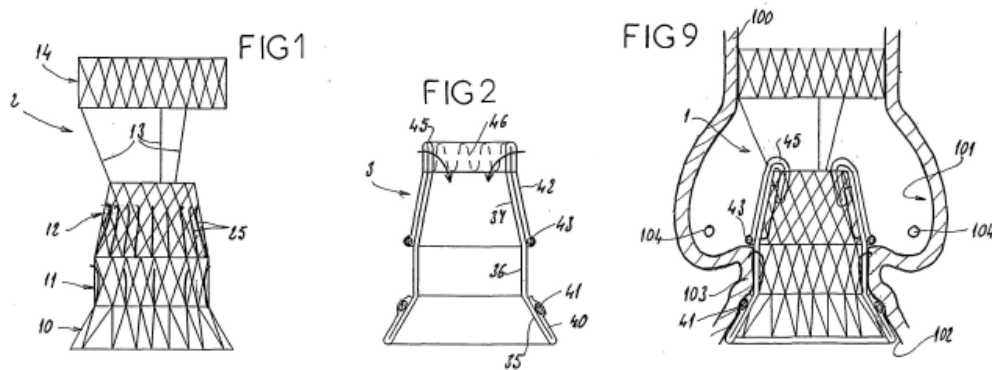

The prosthetic heart valve has a stent body (2) having a proximal end and a distal end and including a generally tubular annulus region (11) and a flare section (10) proximal to the annulus region. The stent body has a proximal-to-distal axis, a radially collapsed condition and an unconstrained fully radially expanded condition, the annulus region and the flare section increasing in diameter during transition from the radially collapsed condition to the radially expanded condition (page 8, lines 16 to 22), the annulus region having a substantially constant diameter and the flare section having a greater diameter than the annulus region when the stent body is in the radially expanded condition (page 8, lines 23 to 26). The prosthetic heart valve further comprises one or more prosthetic valve elements mounted to the stent body and operative to allow flow in the antegrade direction through the annulus region but to substantially block flow in the retrograde direction through the annulus region (Figure 3 and page 7, lines 1 and 2). The prosthetic heart valve further comprises a cuff (3) secured to the stent body, the cuff comprising a first cuff portion (36) covering an exterior surface of the annulus region for disposition at the native valve annulus, the first cuff portion

having a first diameter when the stent body is in the radially expanded condition, and a second cuff portion (35, 40 and 41) proximal to the first cuff portion, the second cuff portion extending along an exterior surface of the flare section of the stent body, and the second cuff portion having a second diameter when the stent body is in the radially expanded condition, the second diameter being greater than the first diameter.

2.2 The proprietor argued that D2 did not disclose that the first and second cuff portions were formed from a unitary sheet of material.

In D2, a cuff within the meaning of claim 1 of the main request is disclosed in Figure 2, with reference numeral 3. In this figure, item 3 is depicted as a unitary element. Moreover, the description of D2 (page 10, lines 8 to 21) defines item 3 as a single element made of a biocompatible material. It refers to item 3 as "gaine 3" having portions 35, 36, 37, 40 and 42 ("rabat 40" and "rabat 42"). Under these circumstances, contrary to the proprietor's argument, the absence of a more explicit mention that the cuff is made of a unitary sheet of material does not leave open the possibility, for the person skilled in the art, that the cuff could be formed from more than one sheet of material. It must rather be concluded that if the authors of D2 had contemplated having the cuff formed from more than one sheet of material, they would have mentioned this.

It follows that D2 provides the person skilled in the art with a direct and unambiguous disclosure of a cuff made from a unitary sheet of material within the meaning of claim 1 of the main request.

2.3 The proprietor argued that D2 did not disclose that the second cuff portion was adapted for engagement with native tissue proximal to the native valve annulus to form a seal with the native tissue which helps to block retrograde flow around the outside of the stent body.

However, D2 expressly discloses that the part of the stent body under the second cuff portion is configured, in the expanded condition, to engage the heart anatomy (page 8, lines 23 to 26). Such a condition, which is shown in Figure 9, means that the second cuff portion must lie on the native tissue proximal to the native annulus. D2 also discloses that the cuff is made of an impermeable material (page 10, lines 8 to 10). An impermeable material in contact with tissue implies a certain sealing action. In this respect it must also be noted that the claim does not define an absolute seal, as the opponent pointed out, but merely requires a seal that "helps to block retrograde flow".

In conclusion, D2 discloses that the second cuff portion is adapted for engagement with native tissue proximal to the native valve annulus to form a seal with the native tissue which helps to block retrograde flow around the outside of the stent body.

2.4 Hence, D2 discloses all the features of claim 1 of the main request. It follows that the main request is not allowable due to lack of novelty (Article 54(1) and (2) EPC) of the subject-matter of claim 1.

3. Auxiliary requests 1 and 2 - admittance into the appeal proceedings

It is common ground that auxiliary requests 1 and 2 correspond to requests which, in the final requests

during the first-instance proceedings, ranked lower than the request found allowable by the opposition division in the impugned decision.

The fact that the proprietor presented these requests on appeal before the request found allowable by the opposition division is an amendment of the proprietor's appeal case within the meaning of Article 12(4) RPBA. In view of this article, admittance of auxiliary requests 1 and 2 is at the board's discretion, which is to be exercised in view of, *inter alia*, the complexity of the amendment, the suitability of the amendment to address the issues which led to the decision under appeal, and the need for procedural economy.

The board notes that the proprietor changed the ranking of its requests during oral proceedings before the opposition division (point 6.1 on page 3 of the minutes), which actively avoided a first-instance decision on current auxiliary requests 1 and 2. Admittance of these auxiliary requests on appeal would have been contrary to the primary object of the appeal proceedings, which is to review the decision under appeal in a judicial manner (Article 12(2) RPBA).

Moreover, auxiliary requests 1 and 2 diverge from the requests considered during the first-instance proceedings. As the opponent observed, they omit the feature of the second cuff portion being thicker than the first cuff portion, present in all the auxiliary requests considered by the opposition division, which correspond to current auxiliary requests 3 to 6. The admittance of auxiliary requests 1 and 2 would have therefore shifted the focus of the discussion, which would have had to consider new aspects for the first time. This would have been detrimental to procedural

economy.

Under these circumstances, it is irrelevant whether auxiliary requests 1 and 2 could be considered a natural fall-back position, as suggested by the proprietor, or whether the opposition division might have admitted them. These requests are not admitted into the appeal proceedings under Article 12(4) RPBA.

4. Auxiliary requests 3 to 5 - added subject-matter

In claim 1 of each of auxiliary requests 3 to 5, it is specified that the second cuff portion is thicker than the first cuff portion.

The proprietor argued that this feature found a basis in paragraph [0057] of the application as filed. However, paragraph [0057] (page 14, lines 12 to 15) reads:

"The second or sub-annular cuff portion 90 also includes a layer of material 120 (FIG. 4) on the interior surface of the flared portion 40 of the stent. Thus, the second or sub-annular portion 90 of the cuff is thicker than the first or supra-annular portion 80."

The teaching of this passage is that the second cuff portion includes a layer of material on the interior of the stent. As a consequence of this layer of material, the second cuff portion is thicker than the first cuff portion. Paragraph [0058] of the application as filed, referred to by the proprietor, discloses other arrangements of the cuff, but does not concern portions with different thicknesses.

The application as filed does not teach or imply any

function associated solely with the increased thickness of the second cuff portion without there being a layer of material on the interior surface of the stent. The proprietor additionally referred to paragraphs [0012] and [0060]. However, paragraph [0012] does not relate to the second cuff portion being thicker than the first cuff portion, but to regions of the cuff arranged around the circumference of the stent body and having differing radial thickness. Paragraph [0060], last sentence, merely discloses that the increased thickness of the second cuff portion is not a problem in terms of delivery of the prosthetic valve.

Introduction into the claims of the feature of the thicker second cuff portion alone, without specifying that this is caused by the presence of an inner layer of material, constitutes an unallowable intermediate generalisation. It provides the teaching, not disclosed in the application as filed, that this feature may have a function independent of the presence of a layer of material on the interior surface of the stent.

Contrary to the proprietor's arguments, the feature of an additional layer of material in claim 1 of auxiliary requests 4 and 5 still does not provide a causal link between the additional layer and the increased thickness of the second cuff portion.

As a consequence, auxiliary requests 3 to 5 are not allowable in view of Article 123(2) EPC, due to added subject-matter in the first claims thereof.

5. Auxiliary request 6 - novelty over D3 or D9

The opponent argued that the subject-matter of

auxiliary request 6 was not novel over either D3 or D9.

5.1 As the opponent argued, D3 discloses a prosthetic heart valve for replacement of a native heart valve having a native valve annulus. Figures 13 and 14 of D3, reproduced below, provide schematic illustrations of a stent body and of a valve, respectively.

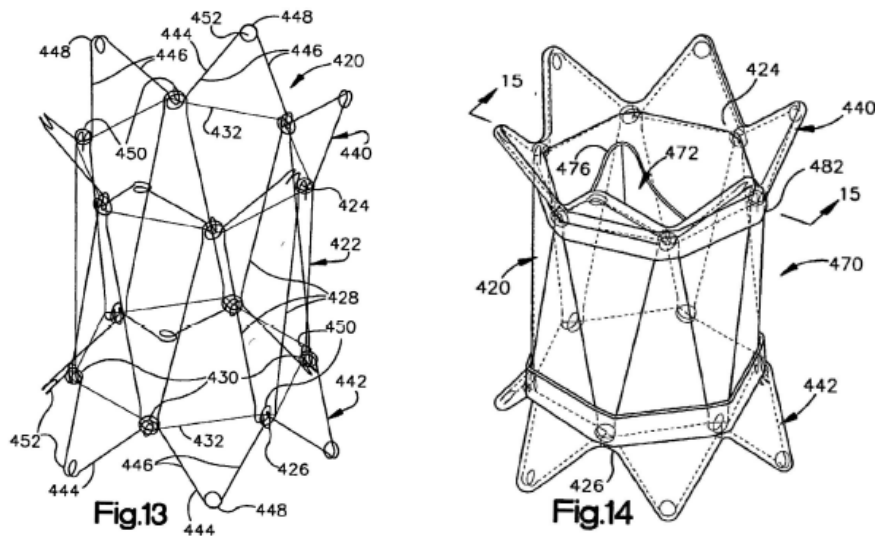

The prosthetic heart valve comprises a stent body (support 420) having a cylindrical intermediate portion (422) and outwardly extending members (442), one or more prosthetic valve elements mounted to the stent body (heart valve 472) and a cuff secured to the stent body (outer sheath 482) and having a first cuff portion (covering cylindrical intermediate portion 422 of the stent body) and a second cuff portion (covering outwardly extending members 442 of the stent body).

As the proprietor submitted, D3 does not disclose a flare section of the stent body covered by an integral layer of material folded around the proximal edge of the stent body within the meaning of claim 1 of auxiliary request 6. Outwardly extending members 442, covered with outer sheath 482, do not form a section

with a proximal end/edge within the meaning of the claim. Moreover, D3 does not directly and unambiguously disclose that the second cuff portion is adapted for engagement with native tissue proximal to the native valve annulus to form a seal with the native tissue which helps to block retrograde flow around the outside of the stent body within the meaning of the claim. Although the claim provides a broad definition of the seal, as the opponent submitted, to the extent that members 442 may engage, in use, with native tissue proximal to the native valve annulus, there is no disclosure that this engagement would provide any sort of seal, as blood could still flow between elements 442.

5.2 It follows that the subject-matter of claim 1 of auxiliary request 6 is novel (Article 54(1) and (2) EPC) over D3.

5.3 D9 discloses a prosthetic heart valve for replacement of a native heart valve having a native valve annulus. Figures 3a and 6d, reproduced below, provide schematic illustrations of a stent body and of a valve, respectively.

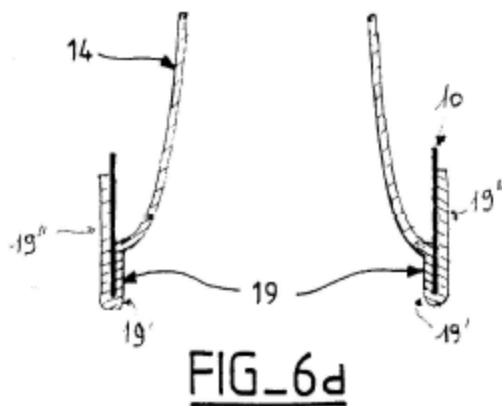
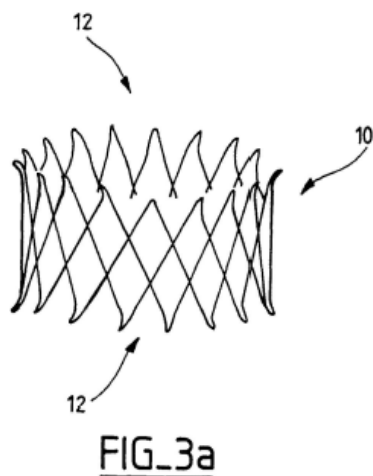

The prosthetic heart valve comprises a stent body (10) having a generally tubular annulus region (linear profile mentioned on page 15, lines 3 to 9) and an opening-out section proximal to the annulus region (opening-out 12, mentioned on page 15, lines 3 to 9), one or more prosthetic valve elements mounted to the stent body (valvular structure 14) and a cuff secured to the stent body (external cover 19'') and having a first cuff portion (covering the annulus region) and a second cuff portion (covering the flare region at the proximal end of the stent body).

D9 does not directly and unambiguously disclose that the second cuff portion is adapted for engagement with native tissue proximal to the native valve annulus to form a seal with the native tissue which helps to block retrograde flow around the outside of the stent body within the meaning of claim 1 of auxiliary request 6. Opening-out sections 12 of the frame in Figure 3a extend over a minimal length. There is no direct and unambiguous disclosure that these sections are configured for engagement, let alone for forming a seal, with native tissue proximal to the native valve annulus. Figures 13j to 13l are schematic and do not show any engagement. Page 15, lines 3 to 9, reads:

"a frame particularly advantageous presents, when deployed in its expanded state, an opening out 12 at both extremities as shown in Figures 3a and 3b, the frame having a linear profile (Figure 3a) or a concave shape profile (Figure 3b). This is aimed at reinforcing the embedding of the IV in the aortic orifice. However, the free extremities of the openings 12 are rounded and very smooth to avoid any traumatism of the aorta or of the myocardium"

It is not directly and unambiguously derivable from this passage whether reinforcement of the embedding is supposed to be a result of the opening-outs or of a concave shape profile. Moreover, even if reinforcement of the embedding were a consequence of the opening-outs, it would still not be directly and unambiguously derivable whether this would result in any sort of seal within the meaning of the claim.

D9 also does not disclose that the second cuff portion is thicker than the first cuff portion. As the proprietor submitted, Figure 6d shows a sheath of material forming the cuff portions which is folded over in the region of the proximal opening-out as well as in a substantial part of the annulus region. Hence, the resulting thickness of the first and the second cuff portions is, at least to a large extent, the same.

5.4 It follows that the subject-matter of claim 1 of auxiliary request 6 is novel (Article 54(1) and (2) EPC) over D9.

6. Auxiliary request 6 - inventive step starting from D7 or D9

The opponent argued that the subject-matter of claim 1 of auxiliary request 6 lacked an inventive step when starting from D7 or D9.

6.1 D7 discloses a prosthetic heart valve for replacement of a native heart valve having a native valve annulus. Figures 1A and 1B, reproduced below, provide schematic illustrations of a stent body and of a valve, respectively.

FIG. 1A

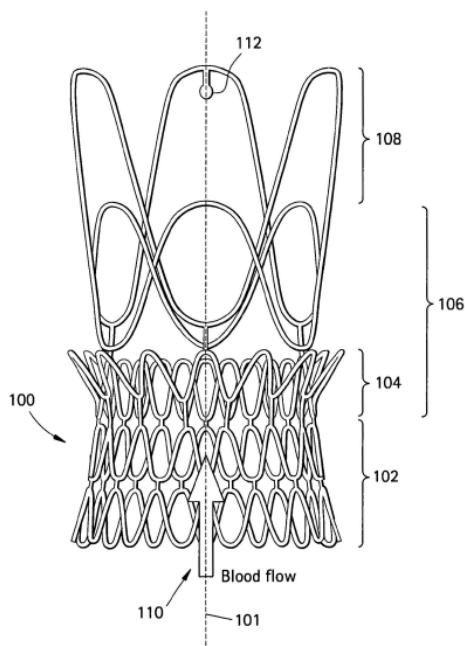
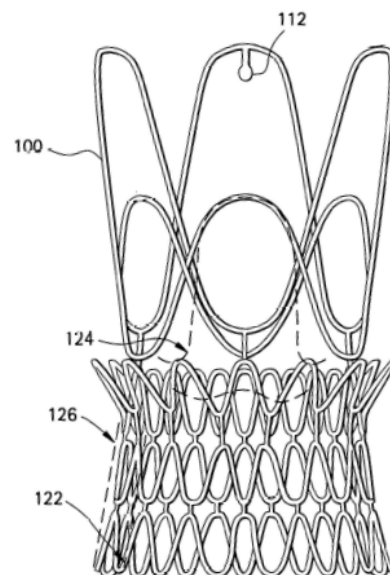

FIG. 1B



The prosthetic heart valve comprises a stent body (Figure 1A) having different sections (102, 104, 106, 108), one or more prosthetic valve elements mounted to the stent body (124, and paragraph [0014]) and a cuff secured to the stent body (outer fabric skirt 126) and having several portions covering the sections of the stent body (paragraph [0071]).

D7 does not disclose a second cuff portion including a layer of material on the interior surface of the stent body, and thus being thicker than a first cuff portion, and wherein the layer of material is integral with the cuff material on the exterior of the stent and is formed by folding the unitary sheet around the proximal edge of the stent body.

In addition, D7 does not disclose that the stent body has a generally tubular annulus region having a substantially constant diameter within the meaning of

claim 1. D7 discloses conical portions of the stent body (Figures 1A and 6, mentioned by the opponent, and paragraphs [0062] to [0067]). The straight portions of the commissure regions shown in Figure 6 do not form a tubular region. The opponent's argument that claim 1 did not define any longitudinal extension of the generally tubular annulus region is not convincing. By defining a generally tubular annulus region with a substantially constant diameter, the claim excludes a mere transition line between two conical portions. Figures 2, 3 and 5 of the patent, referred to by the opponent, do not change this claim construction based on the plain claim wording. Since these figures are schematic in nature, they do not directly and unambiguously disclose a device not covered by said wording. Hence, they cannot contradict this claim construction.

In its objection of lack of inventive step starting from D7, the opponent did not consider this latter distinguishing feature. Hence, it did not demonstrate that this feature would have been obvious to the person skilled in the art.

For this reason alone, the opponent's objection of lack of inventive step (Article 56 EPC) starting from D7 is not convincing and does not prejudice maintenance of the patent on the basis of auxiliary request 6.

- 6.2 As explained above, D9 does not disclose a second cuff portion adapted for engagement with native tissue proximal to the native valve annulus to form a seal with the native tissue which helps to block retrograde flow around the outside of the stent body, irrespective of the possible presence of triangular spaces around the outside of the stent body.

In its objection of lack of inventive step starting from D9, the opponent did not consider this distinguishing feature. Hence, it did not demonstrate that this feature would have been obvious to the person skilled in the art.

For this reason alone, the opponent's objection of lack of inventive step (Article 56 EPC) starting from D9 is not convincing and does not prejudice maintenance of the patent on the basis of auxiliary request 6.

7. Since none of the opponent's objections prejudice maintenance of the patent on the basis of auxiliary request 6, the patent is to be maintained on the basis of this request.

Order

For these reasons it is decided that:

The appeals are dismissed.

The Registrar:

The Chairman:



A. Chavinier-Tomsic

M. Alvazzi Delfrate

Decision electronically authenticated